

TOYOTOMI

 **Γ.Ε. ΔΗΜΗΤΡΙΟΥ α.ε.ε**

TOYOTOMI Heat Pump

hydria⁺ IV

Technical Presentation

TOYOTOMI hydria+IV heat pump

TOYOTOMI

 **Γ.Ε. ΔΗΜΗΤΡΙΟΥ α.ε.ε**

1

**SYSTEM STRUCTURAL
CHARACTERISTICS**

2

SYSTEM ANALYSIS

3

**SYSTEM SOFTWARE
CHARACTERISTICS**

TŌYŌTŌMI

 **Γ.Ε. ΔΗΜΗΤΡΙΟΥ α.ε.ε**

CHAPTER 1

System Structural Characteristics



TŌYŌTŌMI

 Γ.Ε. ΔΗΜΗΤΡΙΟΥ α.ε.ε



General Refrigerant-Hydraulic structure

TŌYŌTŌMI

Γ.Ε. ΔΗΜΗΤΡΙΟΥ α.ε.ε

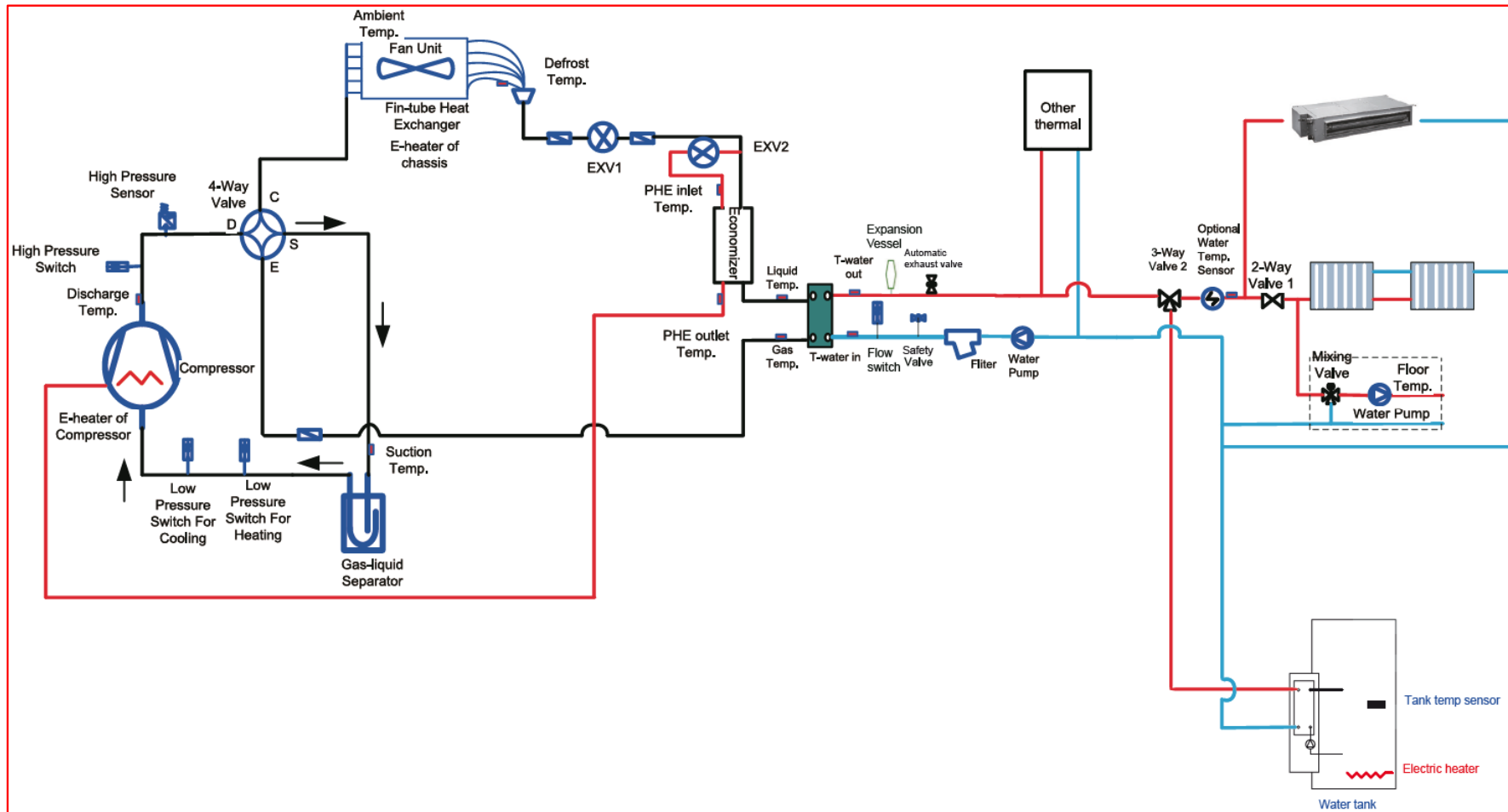

✓ Advantage-High Electrical Voltage Range

TŌYŌTŌMI

Γ.Ε.ΔΗΜΗΤΡΙΟΥ α.ε.ε

■ Single-phase model



■ 3-phase model



✓ Advantage-Twin Rotary Compressor

TŌYŌTŌMI

Γ.Ε.ΔΗΜΗΤΡΙΟΥ α.ε.ε

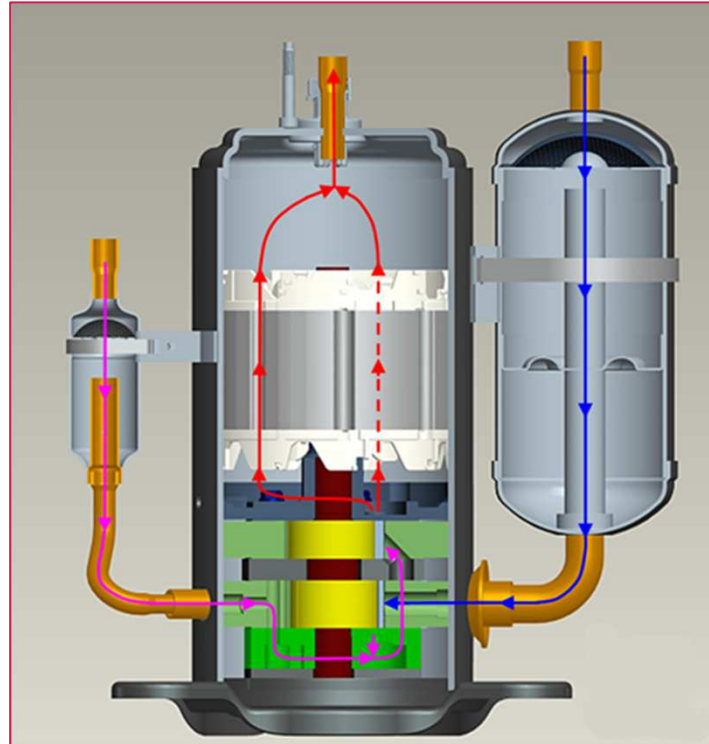

Pros

1. **Compressor Low Temperature exit**
2. **Higher Capacity**

✓ Advantage-EVI technology-(Enhanced Vapour Injection)

TŌYŌTŌMI

Γ.Ε. ΔΗΜΗΤΡΙΟΥ α.ε.ε

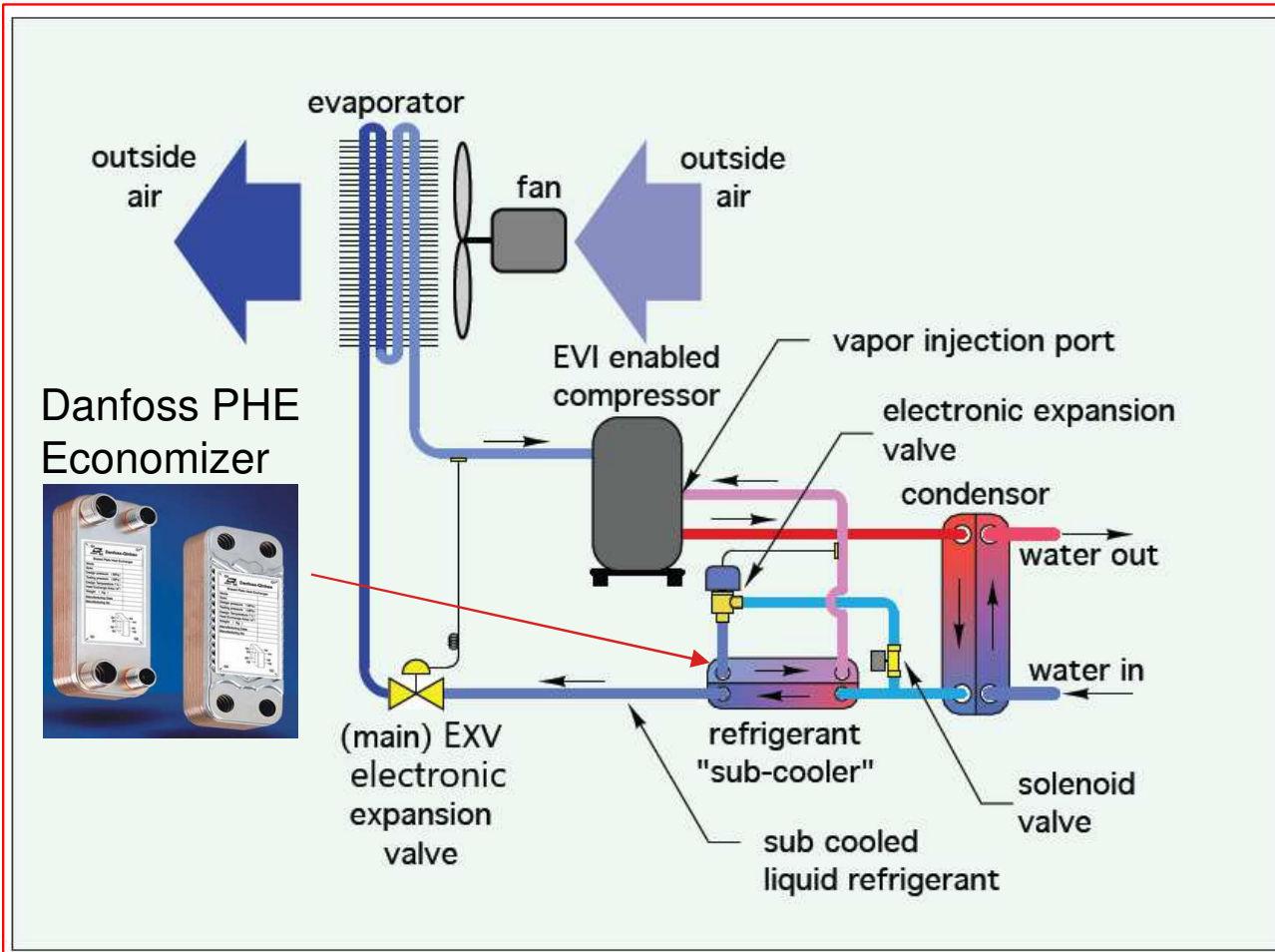

Pros EVI

1. **Maintain High HP Performance for Low Ambient Temperature**
2. **Energy Save due to low compressor load**

√ Advantage-Danfoss Heat Exchanger series H30L-C

TÖYÖTÖMI

Γ.Ε. ΔΗΜΗΤΡΙΟΥ α.ε.ε

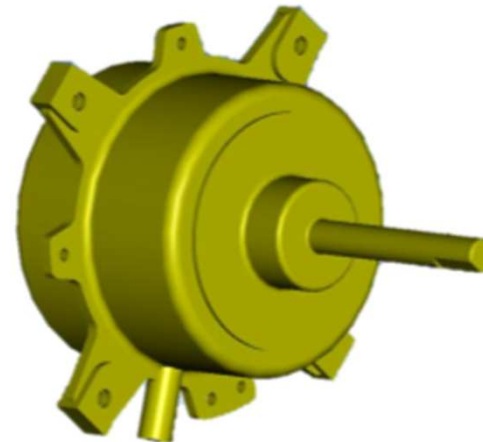
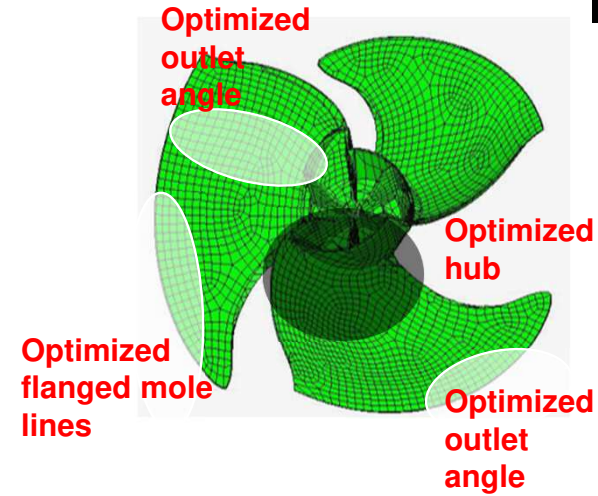
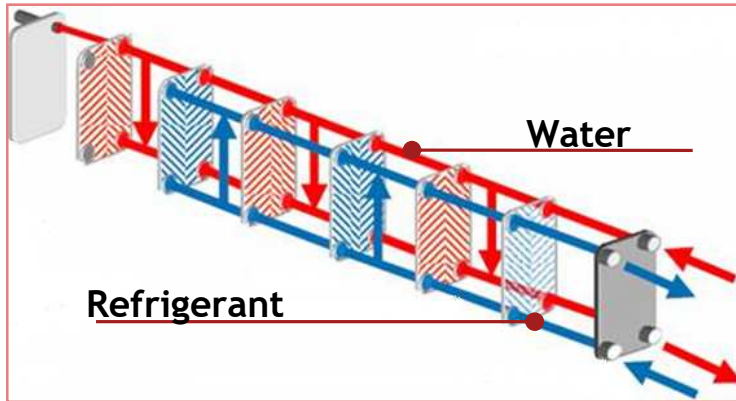

BLDC fan motor control

✓ Advantage- Water Pump Inverter PWM Control logic

Shinhoo 新沪
CANNED MOTOR PUMP

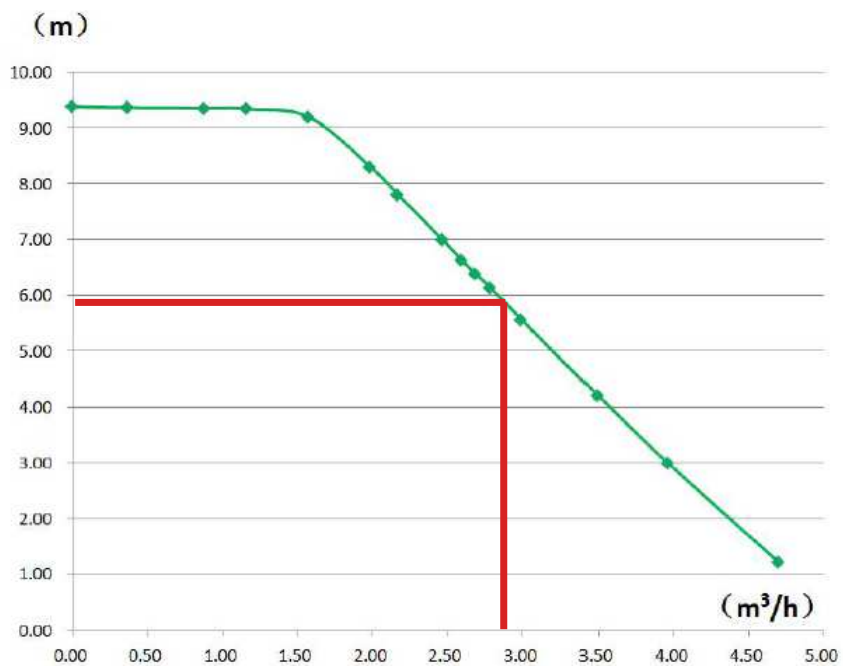

Rated Power: 95W
Max.flow: 4.5m³/h
Max head:9m
Rated Current:0.9A
Voltage/ Frequency: 230V 50HZ/60HZ
Pump housing: Cast iron
Pumped liquid: Water
Insulation class: H
Degree of Protection: IP44
Liquid temperature range: -30-95°C

TŌYŌTŌMI

Γ.Ε.ΔΗΜΗΤΡΙΟΥ α.ε.ε

✓ Advantage-Golden Fin Coating Evaporator Coil

TŌYŌTŌMI

Γ.Ε.ΔΗΜΗΤΡΙΟΥ α.ε.ε

● High Efficiency Fin Tube



- Compared with the flat fin, the heat exchange efficiency of the corrugated fin increase by **5%**

■ Higher corrosion proof fin

Golden fins with better corrosion resistance → Higher air volume & lifespan

Structure	Color	Hydrophilic+ Anticorrosive thickness	Neutral salt spray test	Acid salt spray test
Hydrophilic Layer	Blue	0.8μm~1.4μm	500h	/
Anti-corrosive Alloy	Golden	1.4μm~1.9μm	1,500h	/
Blue Protection Layer	Black	2.2μm~2.7μm	1,500h	200h

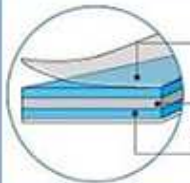

Note: Neutral salt spray test for 24h can be considered for 1 year in regular condition environment

1. Hydrophilic Coating
2. Corrugated Fin Structure
3. Anti-corrosive Alloy Al-Mn

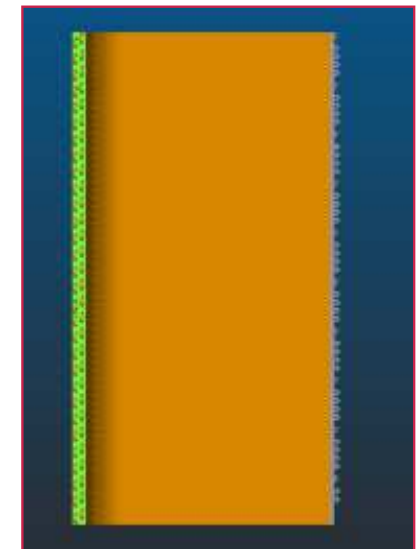

✓ Advantage-Intergraded Thermal Protection

TŌYŌTŌMI

 Γ.Ε. ΔΗΜΗΤΡΙΟΥ α.ε.ε

- ✓ **Crankcase Heater : Oil Preheating & Oil-Refrigerant Separation at the 1st start up**
- ✓ **Ref-Water Heat Exchanger: Freezing Coil protection due to low flow rate**

General PCB Board-Press Connections

TŌYŌTŌMI

Γ.Ε.ΔΗΜΗΤΡΙΟΥ α.ε.ε

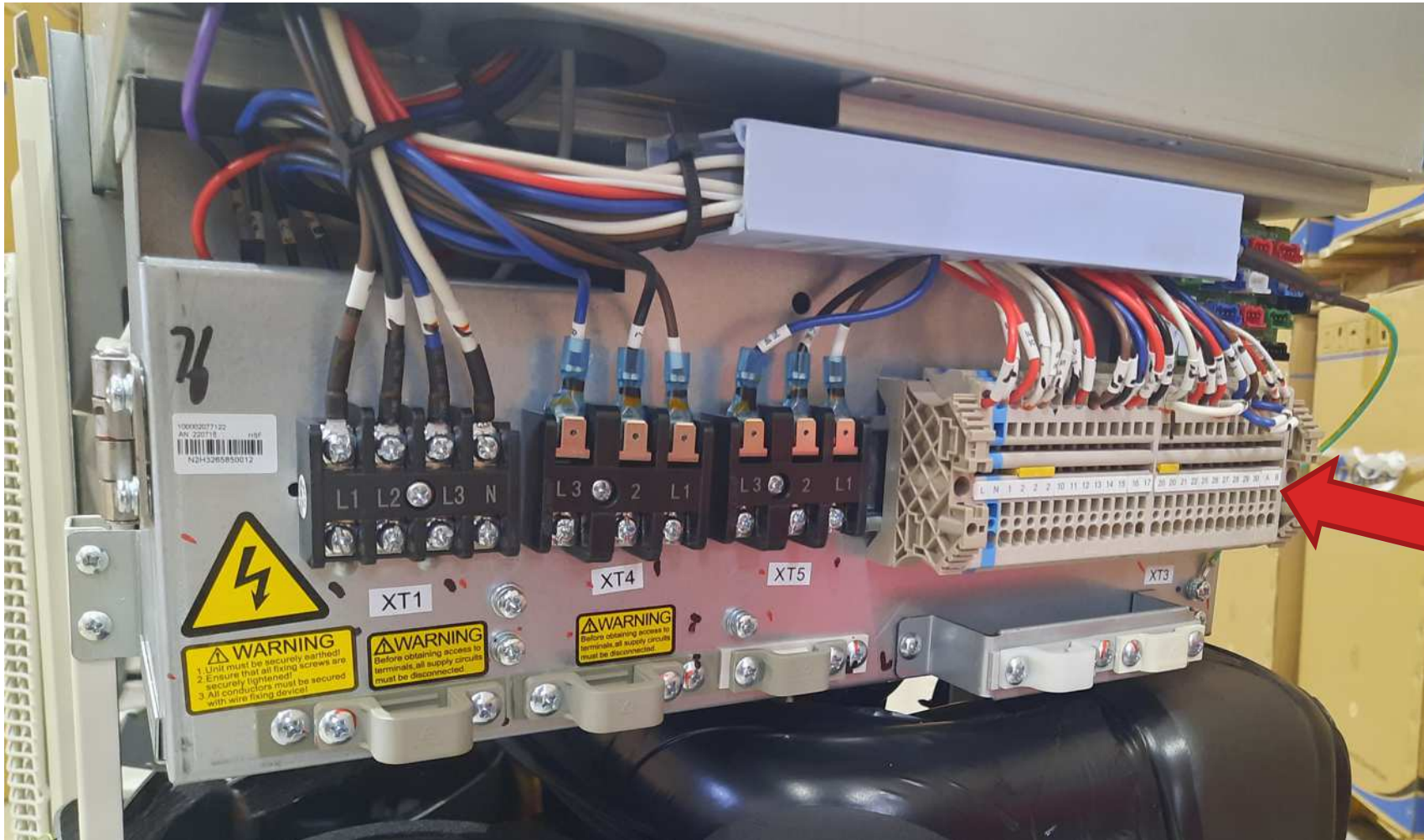

✓ **Advantage-Standard** Central Touch Screen Control Panel 4.3''

TÖYÖTÖMI

Γ.Ε. ΔΗΜΗΤΡΙΟΥ α.ε.ε



Voltage:12V

Factory provided Cable 8m

Recommend Pre Installation: 4x (0.5-0.75)mm² LIYCY (max 30m)

- ✓ **4.3'' Touch-screen Liquid Crystal**
- ✓ **Intergraded Wi-Fi module for direct connection to Wi Fi residential network trough EWPE Smart App**

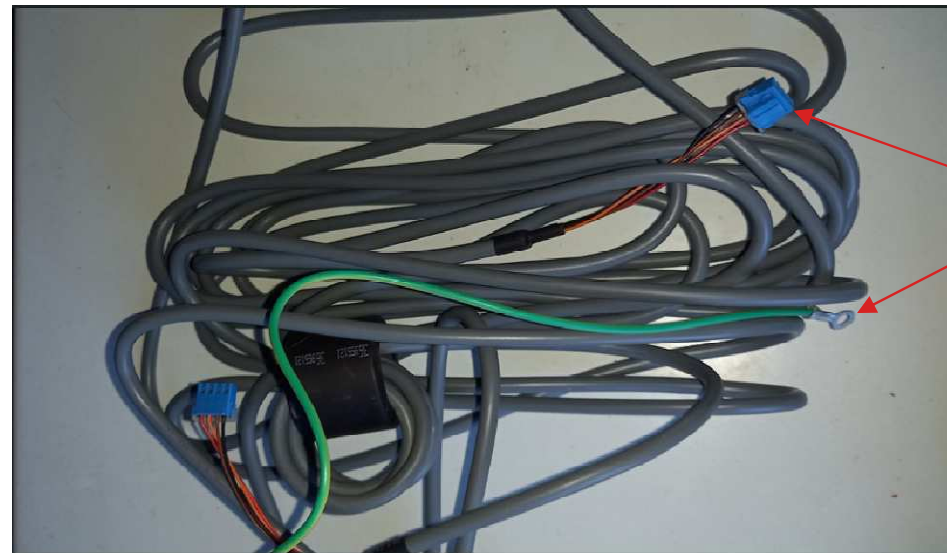

Blue Clip &
Ground Clip!

✓ **TOYOTOMI** Standard Remote Temperature Sensor In-Wall installation (Socket Type)

TOYOTOMI

Γ.Ε.ΔΗΜΗΤΡΙΟΥ α.ε.ε



Remote Sensor Usage

- ✓ 1-zone Temperature Control of the Heat Pump
- ✓ Standard Factory cable of 10m
- ✓ Pre Installation : 2x (0.5-0.75)mm² (max 15m)

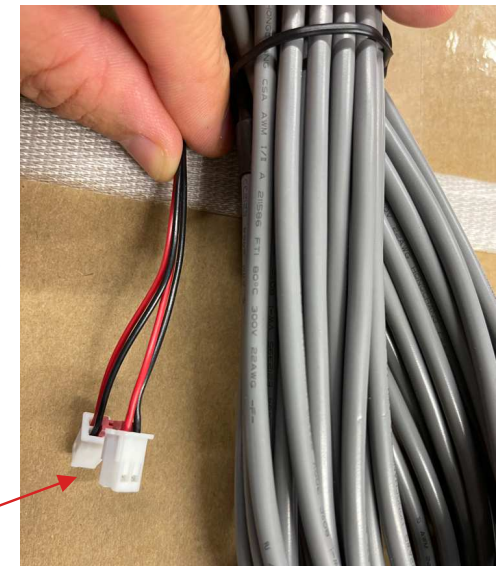
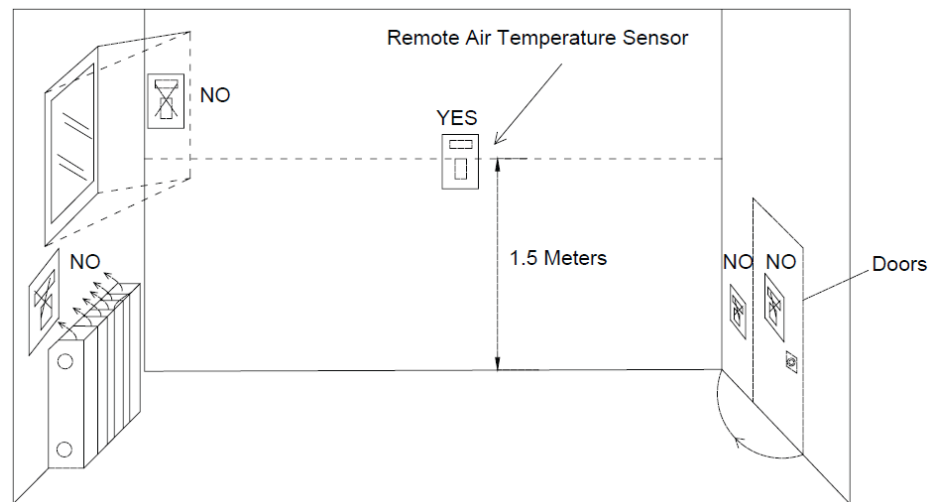

White Clip!

✓ Advantage-Other Sensors

TŌYŌTŌMI

Γ.Ε. ΔΗΜΗΤΡΙΟΥ α.ε.ε

Standard 20m DHW Sensor

Standard 6m Optional Water Temp Sensor



Yellow Clip!

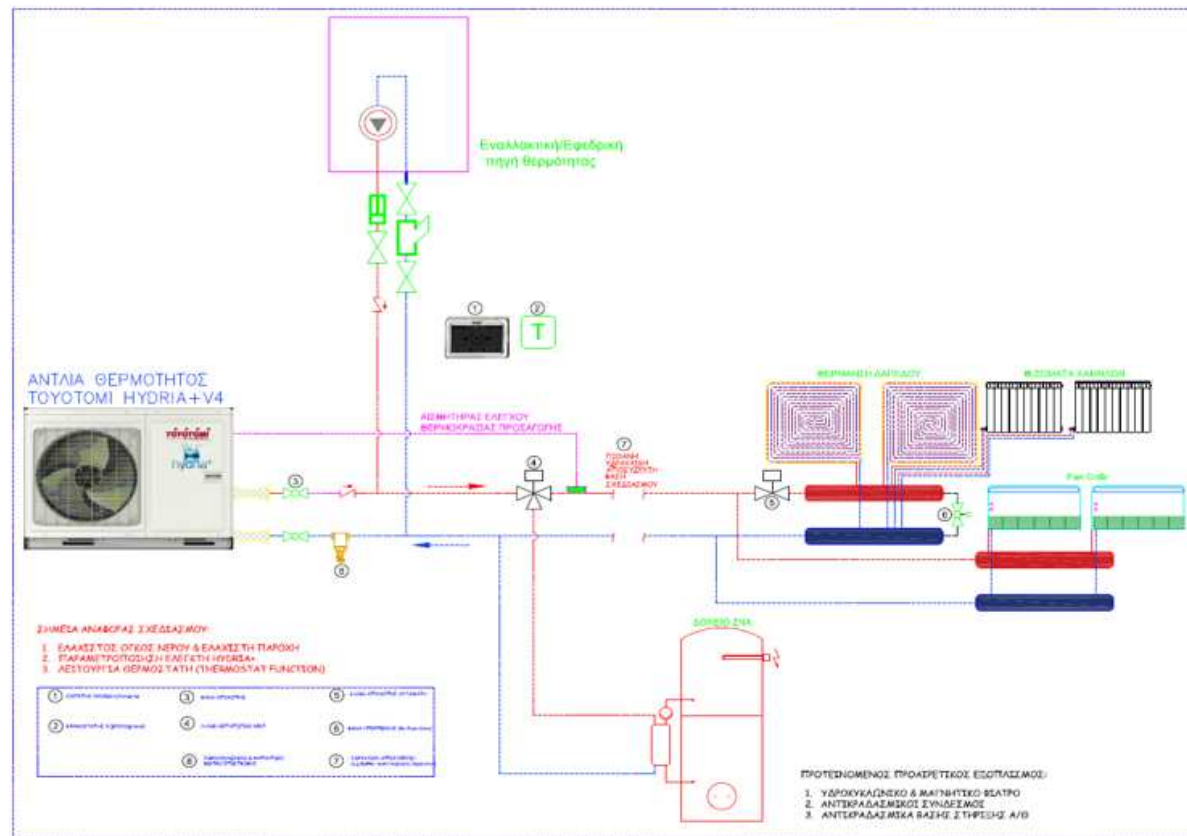

Red Clip!



TŌYŌTŌMI

 **Γ.Ε. ΔΗΜΗΤΡΙΟΥ α.ε.ε**

CHAPTER 2

SYSTEM ANALYSIS

➤ **3 Operational Modes-Control Logic**

- ✓ According **Water Outgoing Temperature (WOT)** controlled by Touch screen panel
- ✓ According TOYOTOMI Remote Sensor
- ✓ According Market Room Thermostat

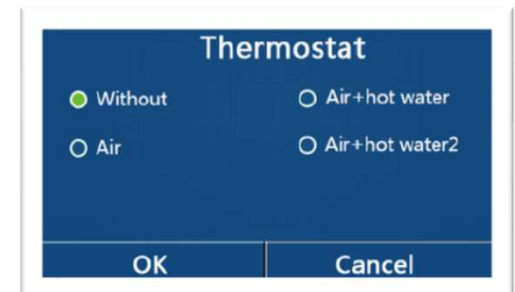
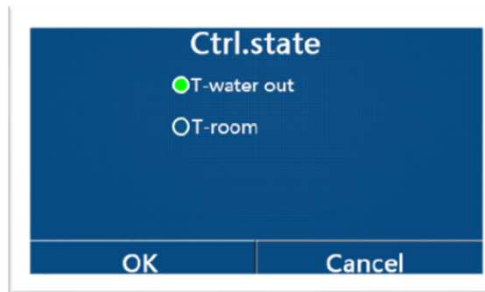

1	Ctrl. state	T-water out/T-room	T-water out
---	-------------	--------------------	-------------

Remote sensor	With/Without	Without
---------------	--------------	---------

7	Thermostat	Without/Air/Air+ hot water/ Air+ hot water2	Without
		On/Off	Off

➤ Gate Control/Key Card Function/Remote ON-OFF

TŌYŌTŌMI

Γ.Ε.ΔΗΜΗΤΡΙΟΥ α.ε.ε



Terminal board XT3

L	N	1	2	10	2	11	2	12	13	14	15	16	17	20	21	22	20	25	26	27	28	29	30	A	B	
Gate-controller		Other thermal		Water Pump (OUT)		Water tank Pump power		Thermostat					2-way valve1		3-way valve2		3-way valve1		Pump control signal (OUT)		Water tank pump control signal		Water heating		A	B

XT3



230VAC



➤ **Other Thermal Function (Oil or Gas Boiler) → Alternate operation**
Logic: Replace the heat pump for Low Ambient temperature

TŌYŌTŌMI

Γ.Ε. ΔΗΜΗΤΡΙΟΥ α.ε.ε

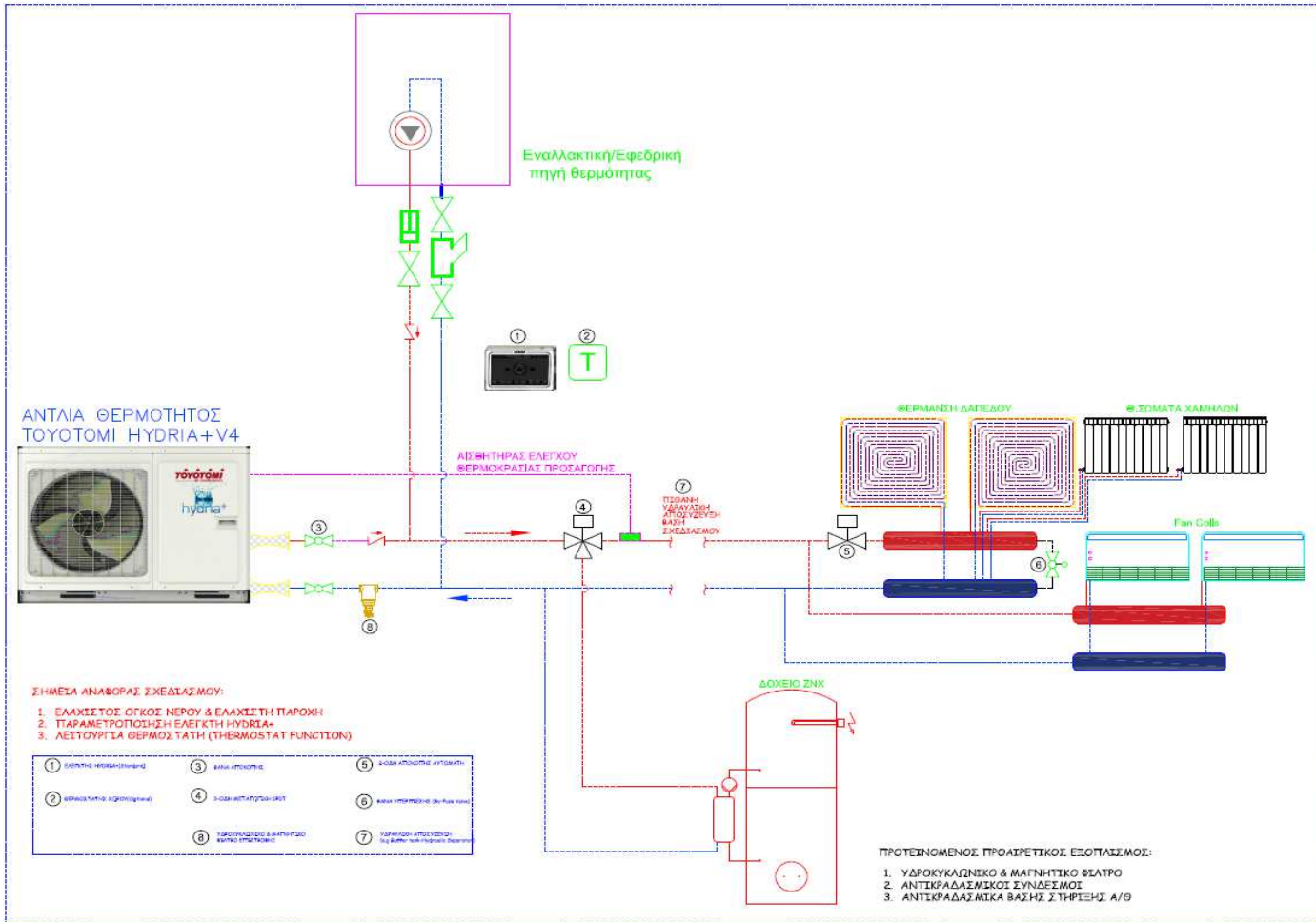

Other thermal	With/Without	Without
---------------	--------------	---------

- ✓ 3 Control Logic
- ✓ Installation of Optional Water Temp. Sensor

➤ Optional E-Heater In Parallel —→ In Parallel operation Logic: Support the heat pump for Low Ambient temperature

Terminal board XT3

L	N	1	2	10	2	11	2	12	13	14	15	16	17	20	21	22	20	25	26	27	28	29	30	A	B
Gate-controller		Other thermal		Water Pump (OUT)		Water tank Pump power		Thermostat				2-way valve1		3-way valve2		3-way valve1		Pump control signal (OUT)		Water tank pump control signal		Water heating			

Optional E-Heater	Off/1/2	Off
-------------------	---------	-----

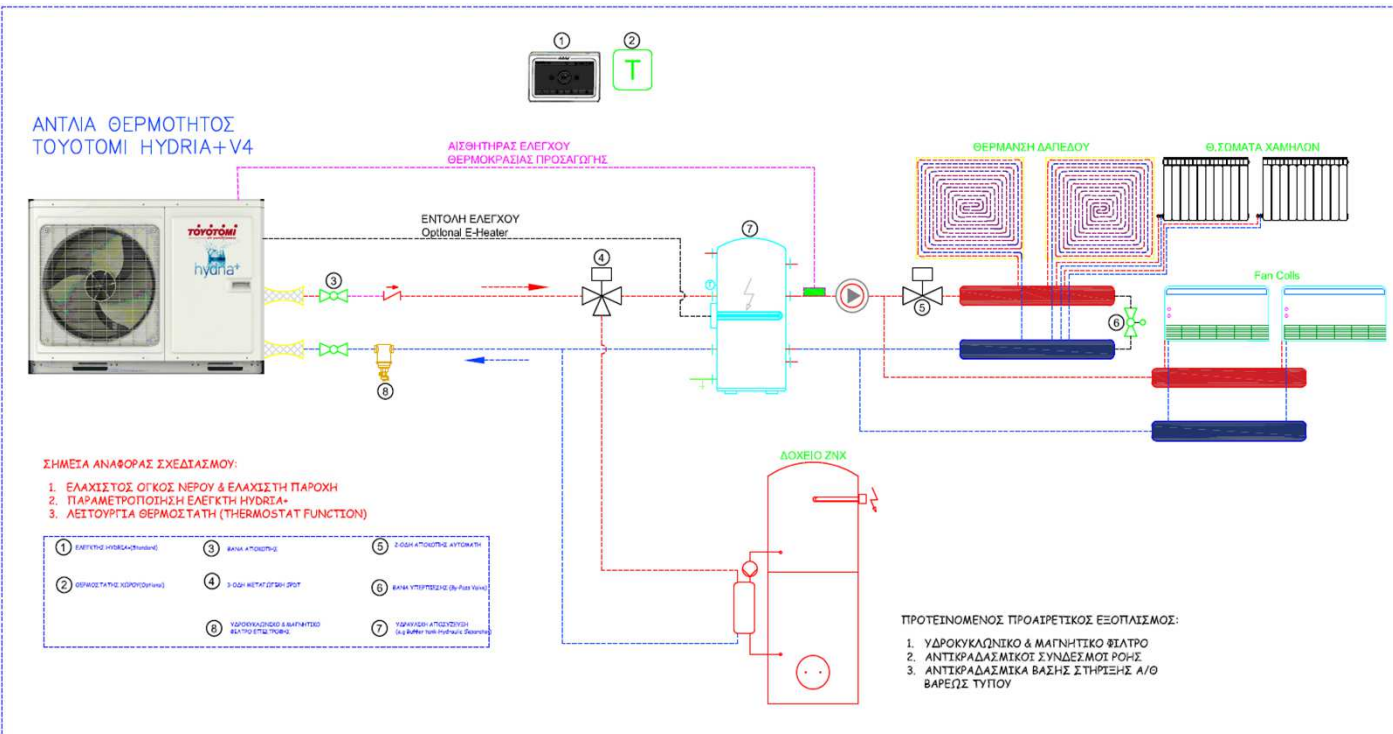

✓ 2 Control Logic

✓ Installation of Optional Water Temp. Sensor

Other Thermal & Optional E-heater output is the same! Only one can work

➤ 2nd Water Pump Control 230V ON-OFF & PWM signal

Terminal board XT3

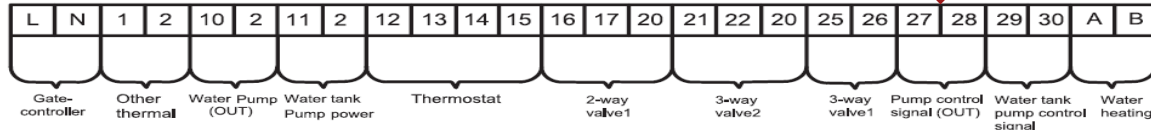

PWM signal 2nd Water Pump

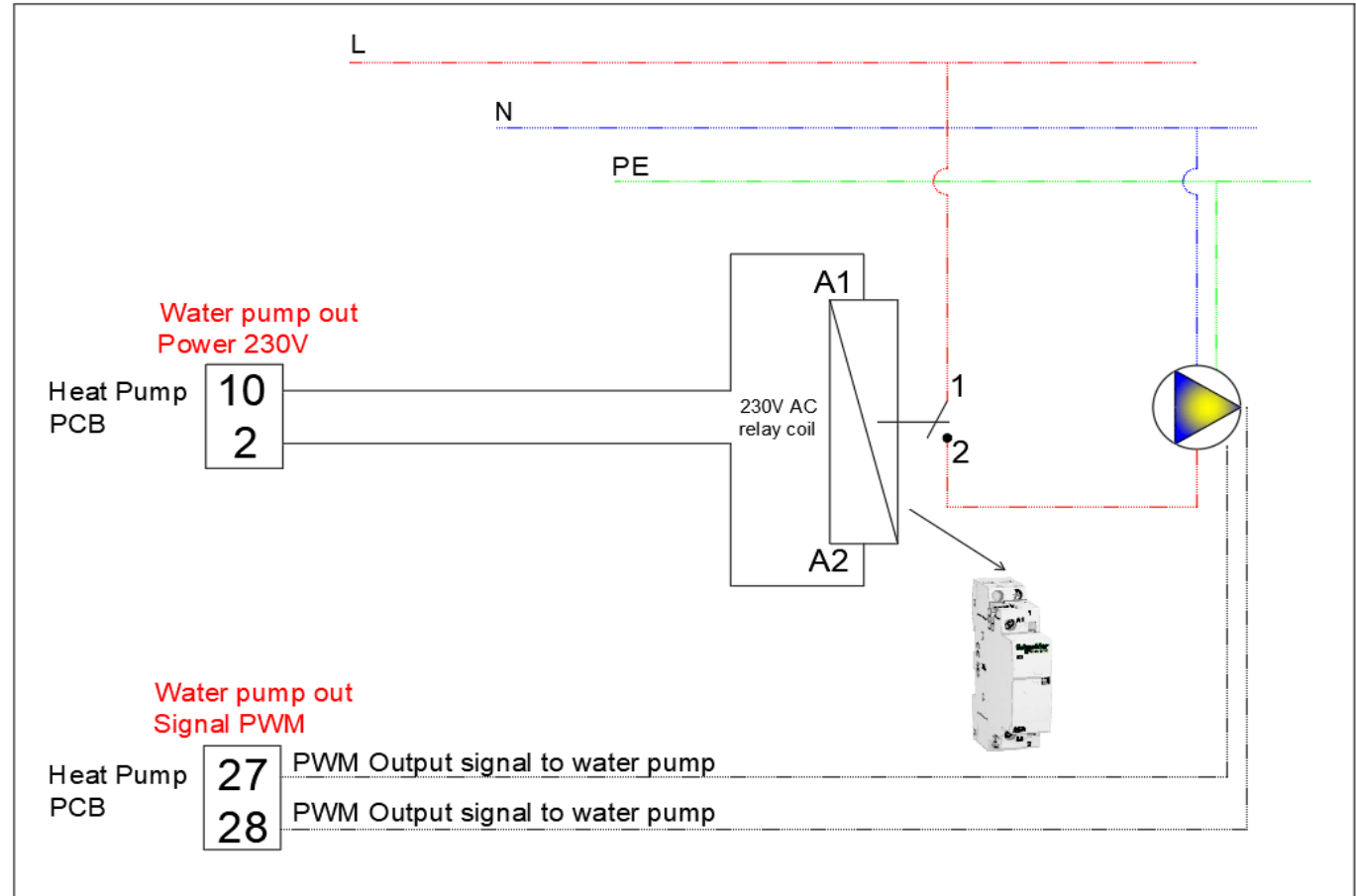

TŌYŌTŌMI

Γ.Ε.ΔΗΜΗΤΡΙΟΥ α.ε.ε

➤ 2nd DHW Water Tank Pump Control 230V ON-OFF & PWM signal

TŌYŌTŌMI

Γ.Ε.ΔΗΜΗΤΡΙΟΥ α.ε.ε

Terminal board XT3

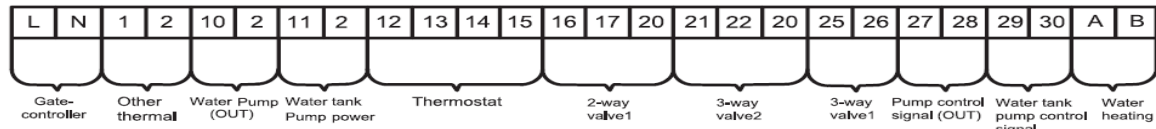

PWM signal 2nd DHW Water Pump

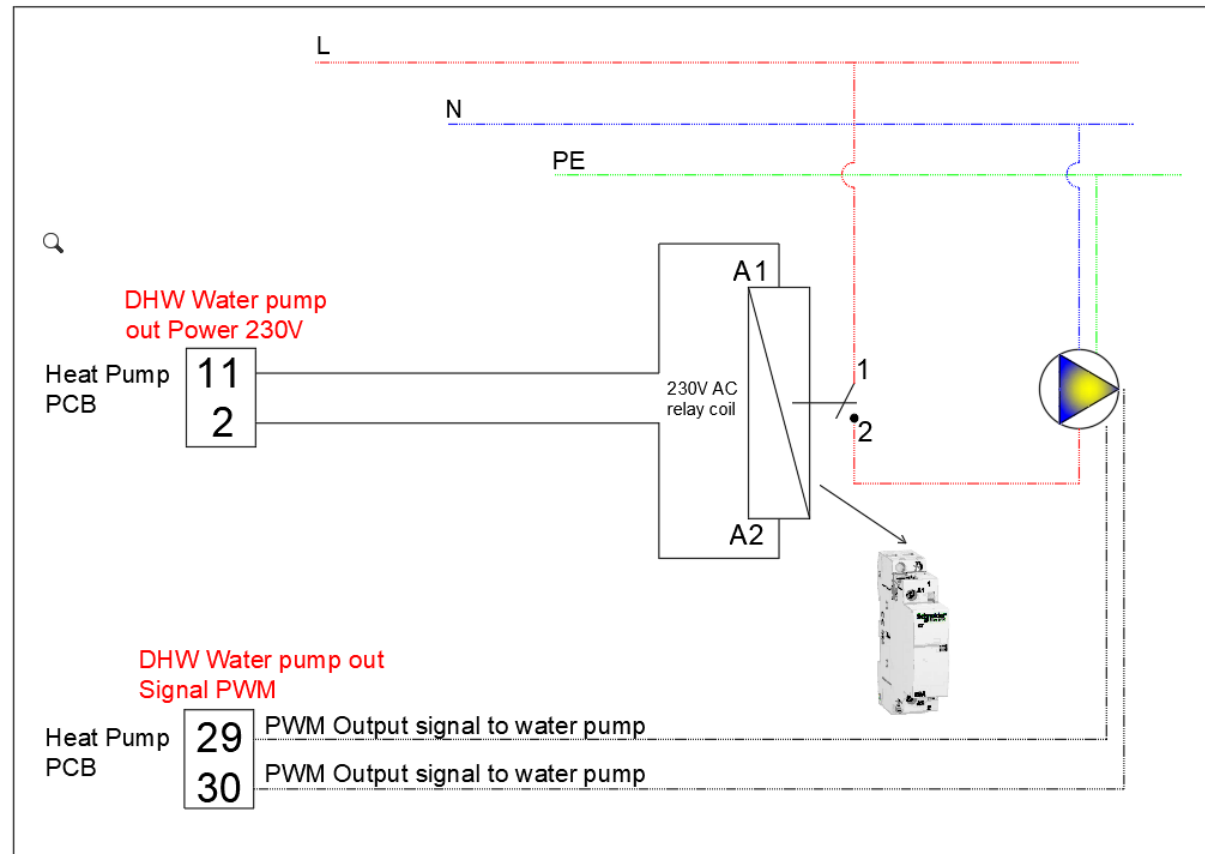

➤ Thermostat Function (Market Thermostat)

TŌYŌTŌMI

Γ.Ε.ΔΗΜΗΤΡΙΟΥ α.ε.ε

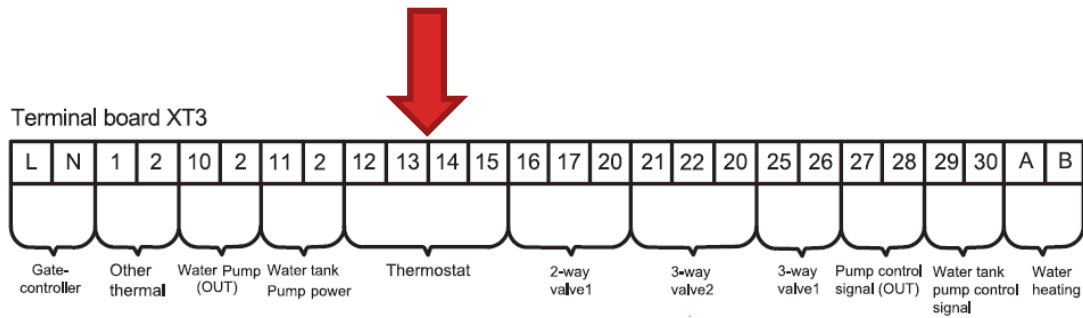

Thermostat

Without

Air

Air+hot water

Air+hot water2

OK
Cancel

Thermostat	Without/Air/Air+ hot water/ Air+ hot water2	Without
	On/Off	Off

Parameter Selection of:

1. H-C
2. H-C & DHW
3. H-C & DHW with user Priority

Thermostat–One Zone Control-Direct Logic

TŌYŌTŌMI

Γ.Ε.ΔΗΜΗΤΡΙΟΥ α.ε.ε

hydria+ thermostat function_ One Zone Control_Direct logic

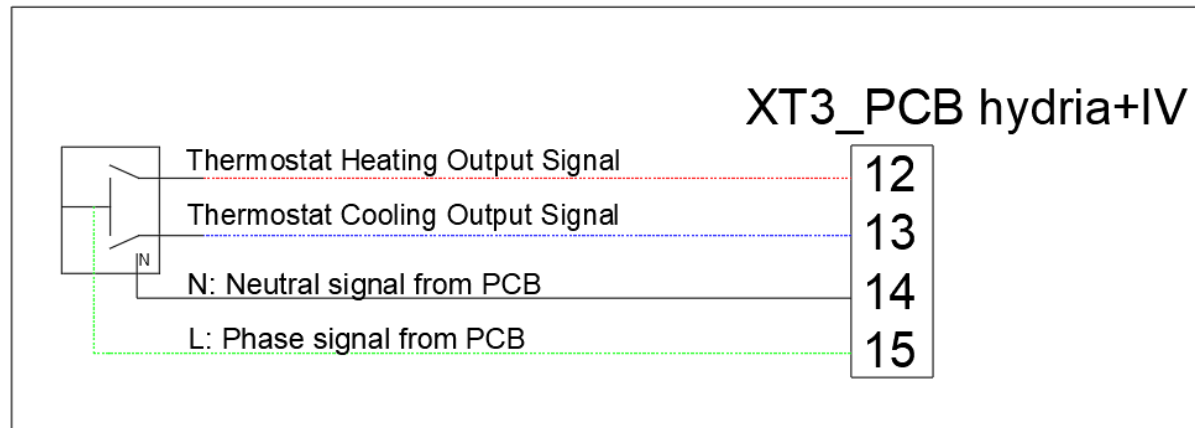

Thermostat-Multi Zone Control-Relays Logic

hydria+ thermostat function_ Multi Zone Heating Control

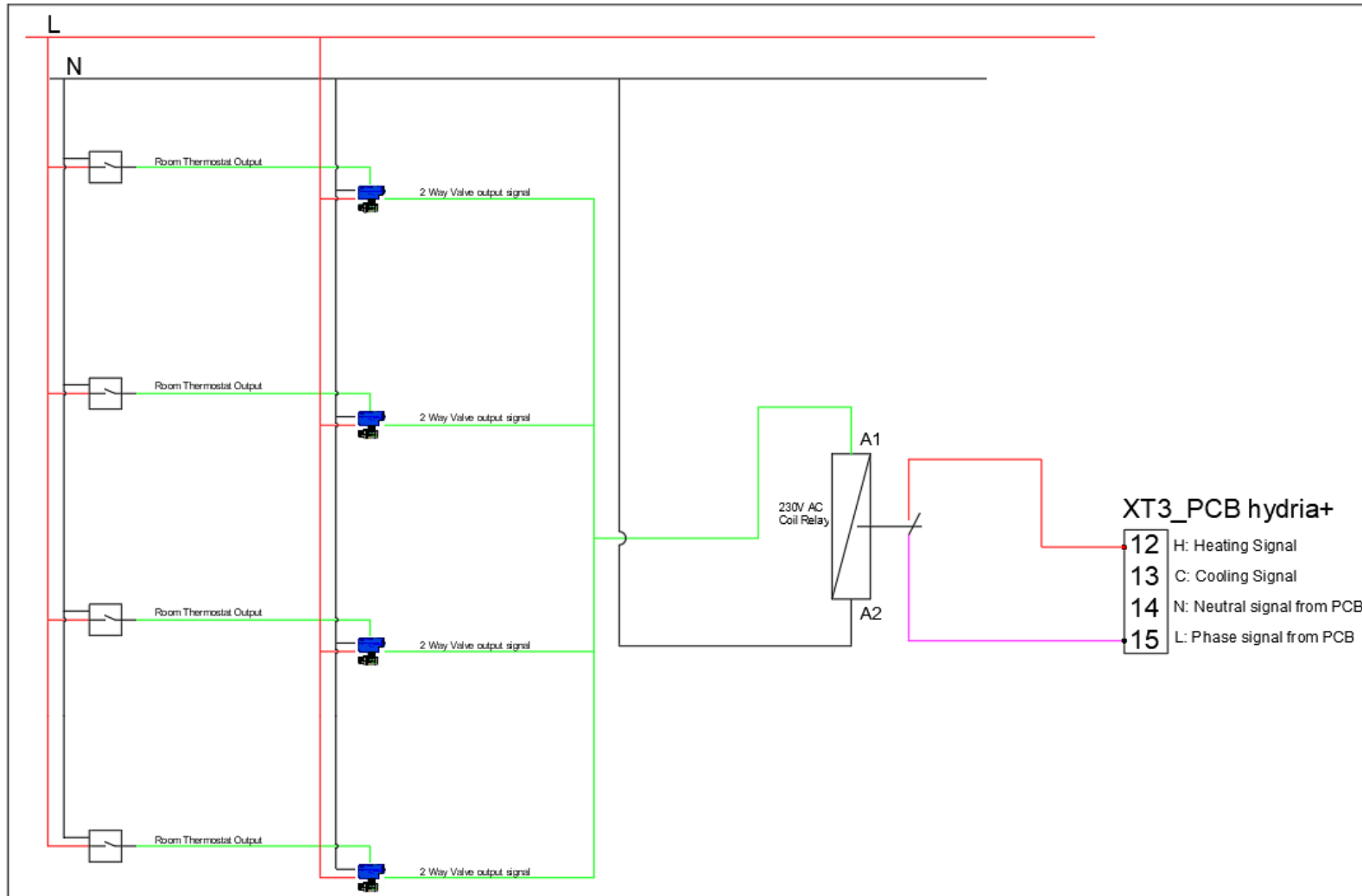

TÖYÖTÖMI

Γ.Ε. ΔΗΜΗΤΡΙΟΥ α.ε.ε

S.O.S !

- ✓ **Mandatory hydraulic separation by:**
- Hydraulic bridge
- Buffer tank

Thermostat function-User s Priority

TŌYŌTŌMI

Γ.Ε. ΔΗΜΗΤΡΙΟΥ α.ε.ε

Terminal board XT3

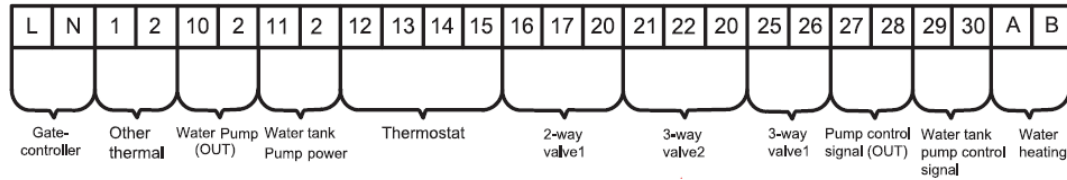

User s Priority ONLY FOR THERMOSTAT FUNCTION:
Select Air +hot water 2!

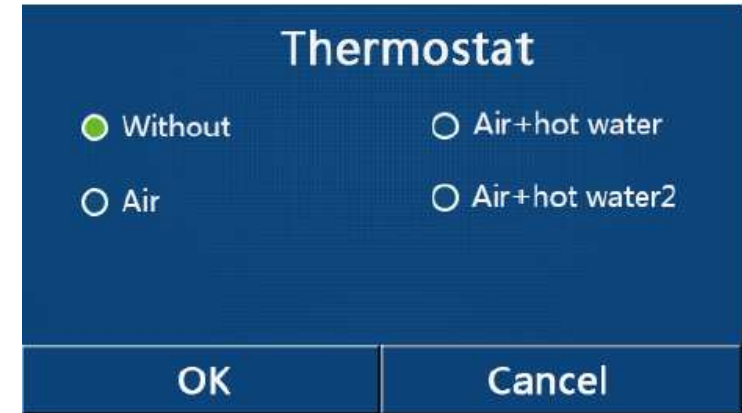
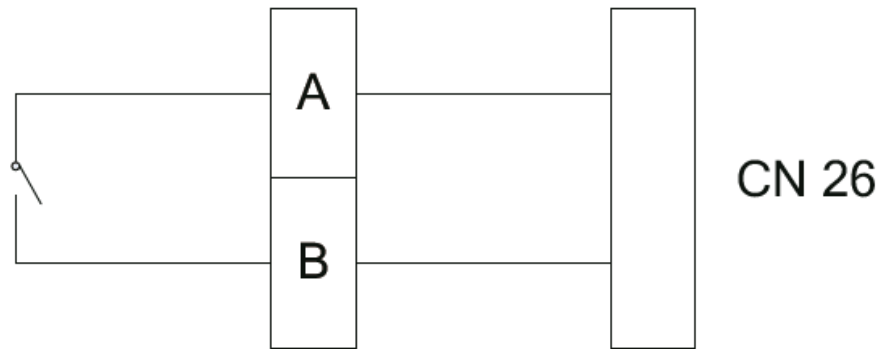

- Contact Open: DHW Priority
- Contact Close: Heating Priority

➤ 2 Way Valve Control/Cut off signal for Cooling & Heating

TOYOTOMI

Γ.Ε.ΔΗΜΗΤΡΙΟΥ α.ε.ε

Basic System 3 :
HYDRIA+ & ΘΕΡΜΑΝΣΗ ΔΑΠΕΔΟΥ/ΣΩΜΑΤΑ ΧΑΜΗΛΩΝ ΚΑΙ FAN COILS

ΑΝΤΛΙΑ ΘΕΡΜΟΤΗΤΟΣ
TOYOTOMI HYDRIA+ R-32

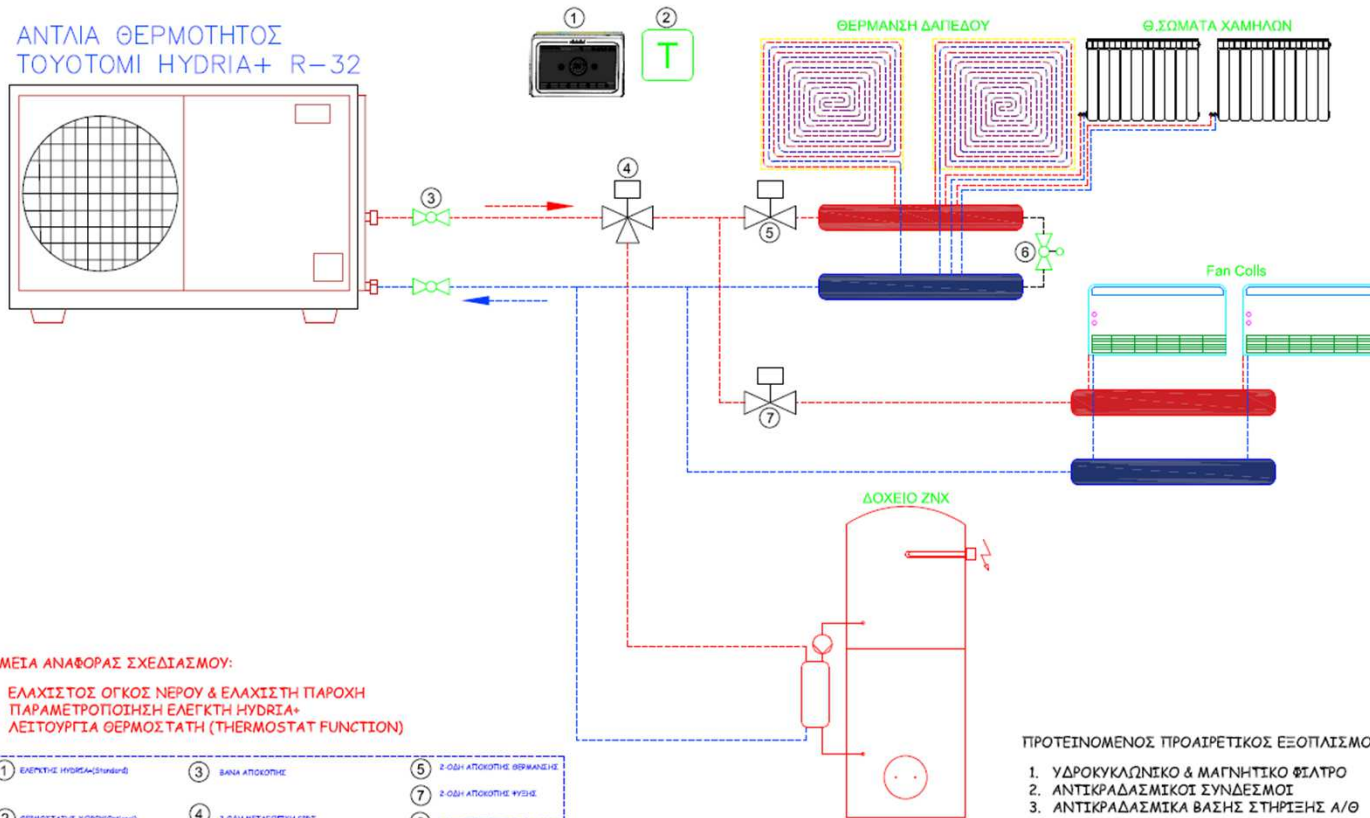

2-Way valve	Cool 2-Way valve, On/Off	Off
	Heat 2-Way valve, On/Off	On

Valve control

➤ **5** Heating Valve

➤ **7** Cooling Valve

➤ 2 Way Valve Control/Cut off signal for Cooling & Heating

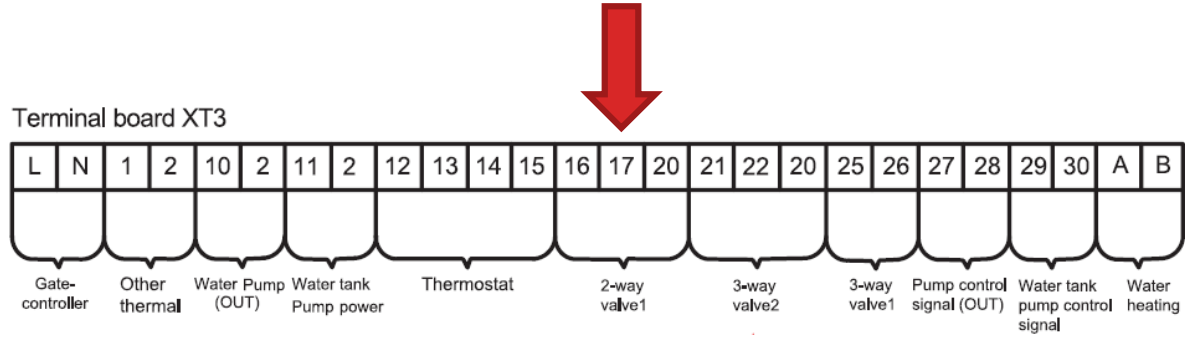

2	2-Way valve	Cool 2-Way valve, On/Off	Off
		Heat 2-Way valve, On/Off	On

Type	Power	Operating Mode	Supported
NO 2-wire	230V 50Hz ~AC	Closing water flow	Yes
		Opening water flow	Yes
NC 2-wire	230V 50Hz ~AC	Closing water flow	Yes
		Opening water flow	Yes

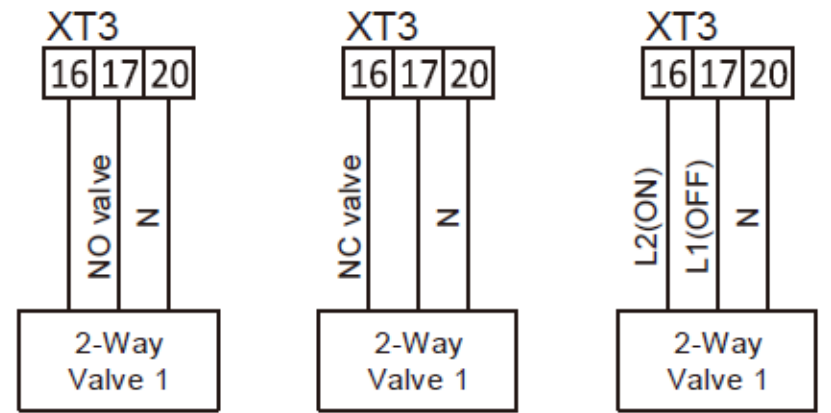
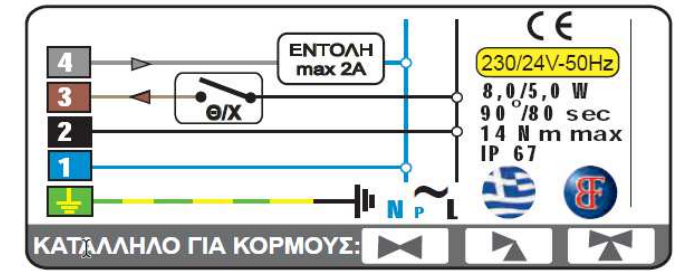

➤ 2 Way Valve Control/Cut off signal for Cooling & Heating

2 Way valve-ON/OFF-Relay Logic

Attention! For 3 Ph systems please use the same phase!

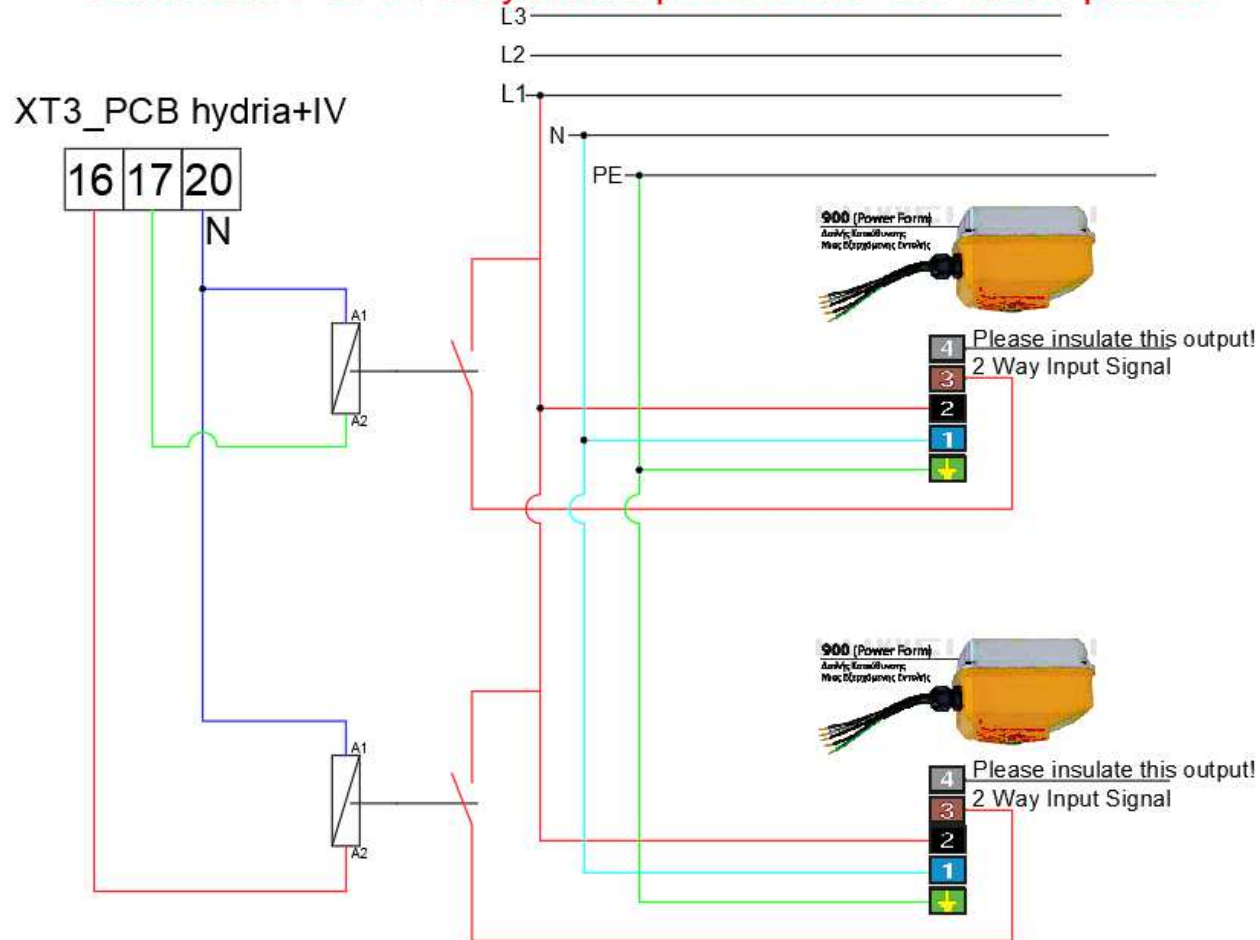

TŌYŌTŌMI

Γ.Ε.ΔΗΜΗΤΡΙΟΥ α.ε.ε

➤ 2 Way Valve Control/Cut off signal for Cooling & Heating

2 Way Valve-ON/OFF-Direct Logic

Attention! For 3 Ph systems please use L1!

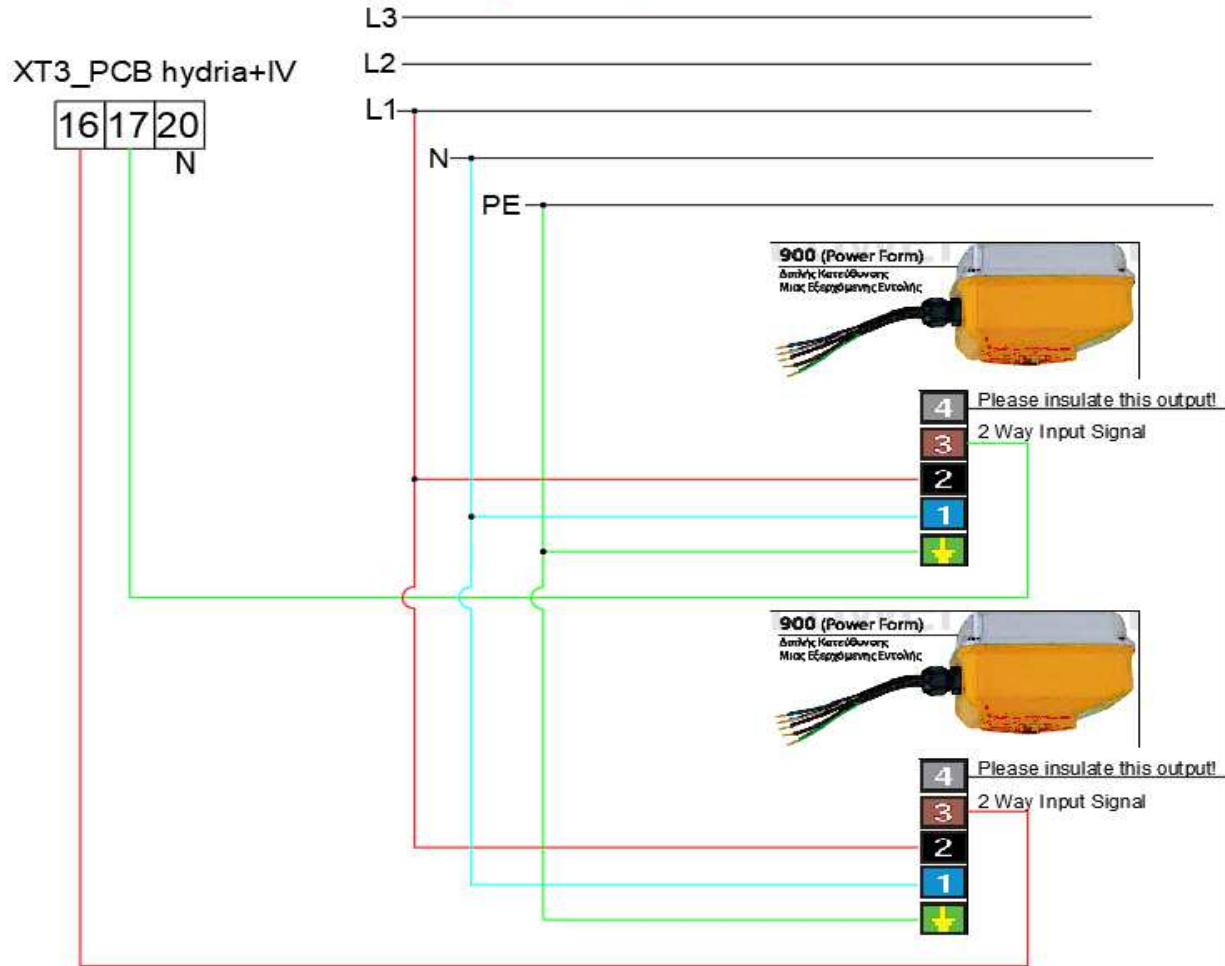

TŌYŌTŌMI

Γ.Ε.ΔΗΜΗΤΡΙΟΥ α.ε.ε

➤ **DHW 3 Way Valve 2 Output signal 230V Control/Change over signal**



Terminal board XT3

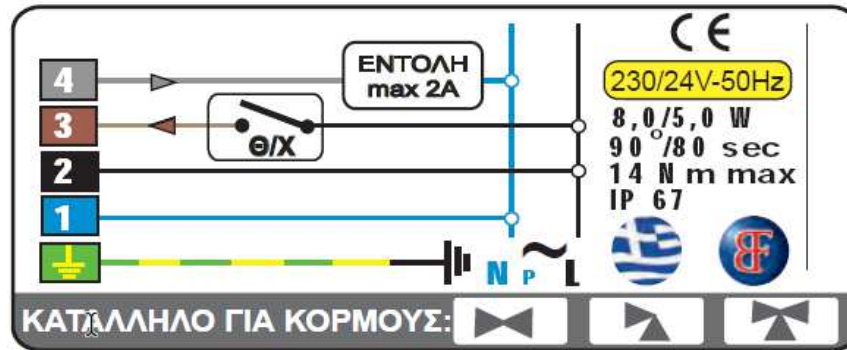
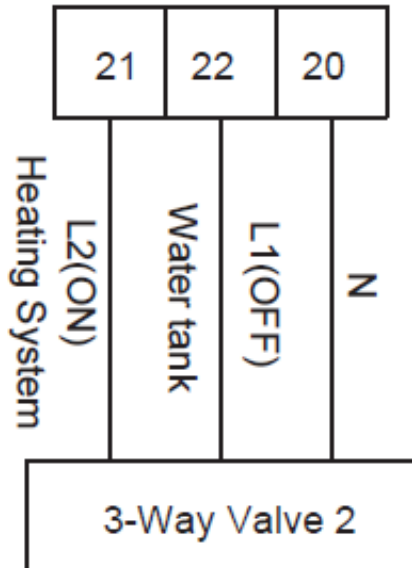
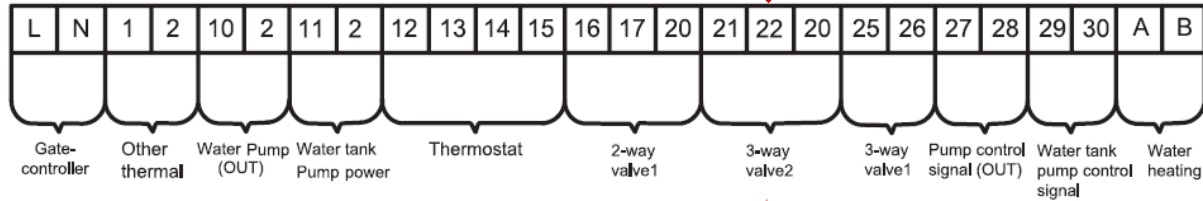

Water tank	With/Without	Without
------------	--------------	---------

➤ Change Over 3 Way Valve for DHW Function-Relay Control

TŌYŌTŌMI

Γ.Ε.ΔΗΜΗΤΡΙΟΥ α.ε.ε

3 Way DHW & Relais_3Ph hydria+IV

Attention! For 3 Ph systems please use the same phase!

hydria+ IV PCB

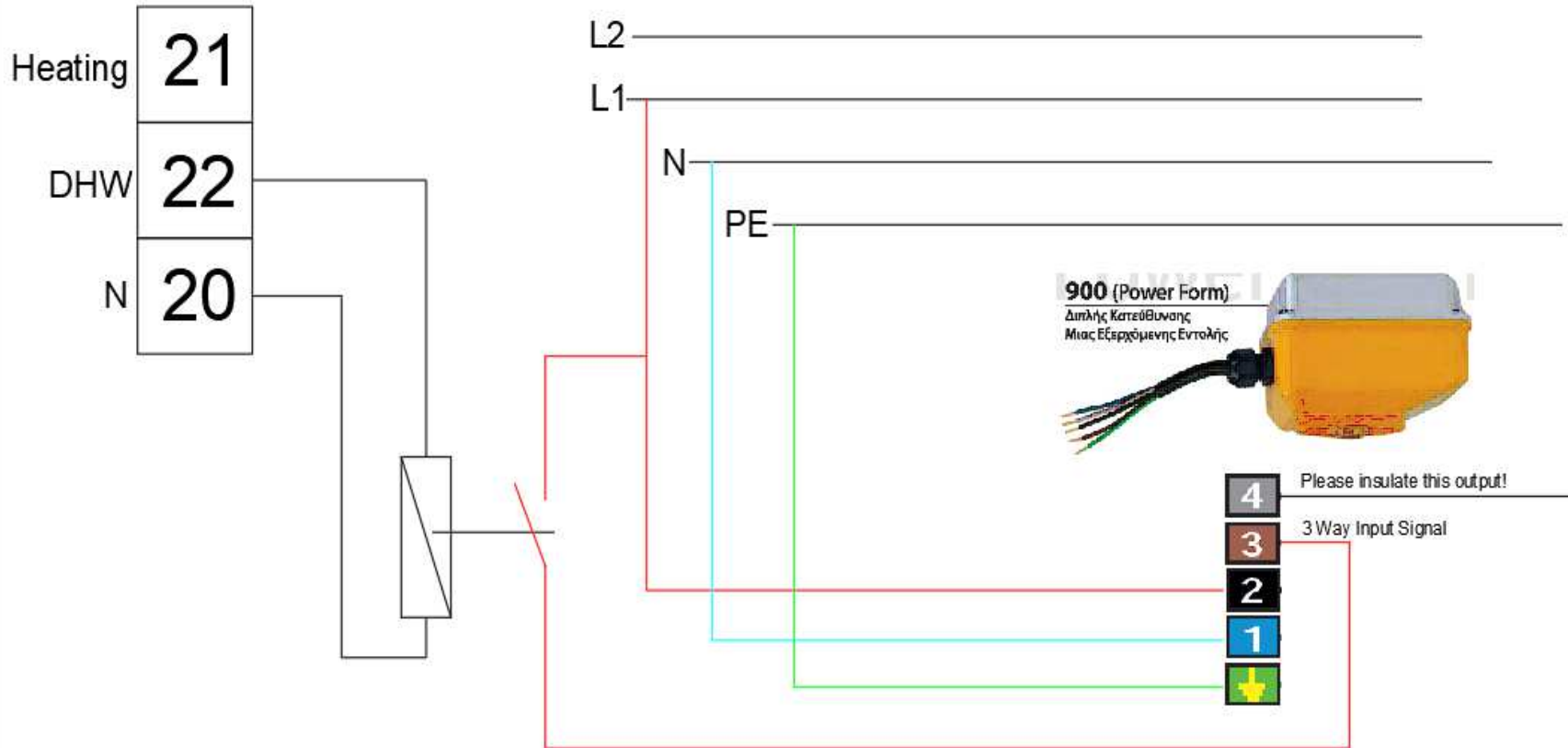

- 4 Please insulate this output!
- 3 3 Way Input Signal
- 2
- 1
- ↓

➤ Change Over 3 Way Valve for DHW Function-Direct Control

3 Way DHW & Direct Logic_3Ph hydria+IV
Attention! For 3 Ph systems please use L1!

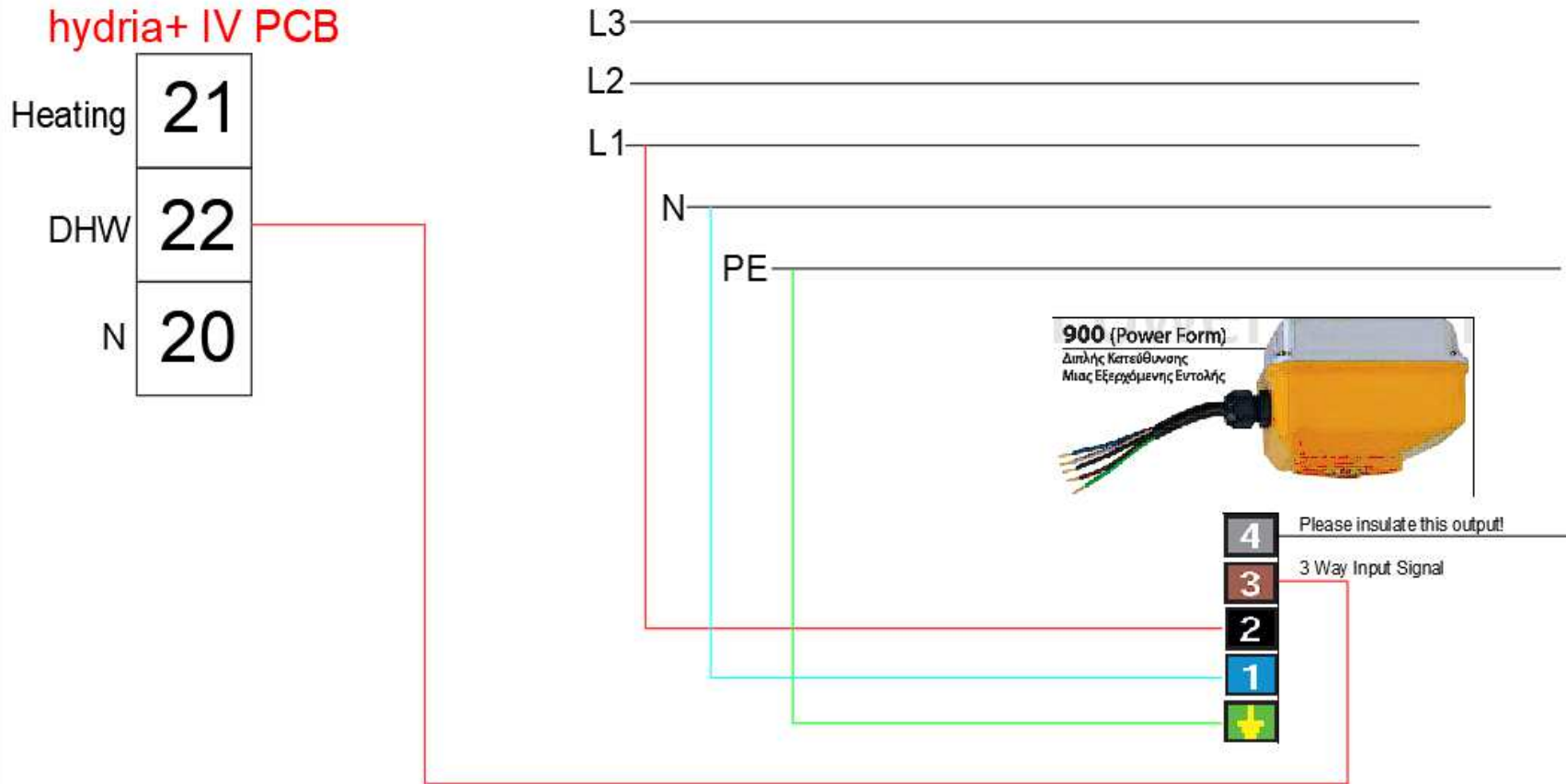

TŌYŌTŌMI

 Γ.Ε. ΔΗΜΗΤΡΙΟΥ α.ε.ε

➤ **Control Logic of Water Tank E-Heater**



- ✓ 2 Control Logic
- ✓ Integrated relay

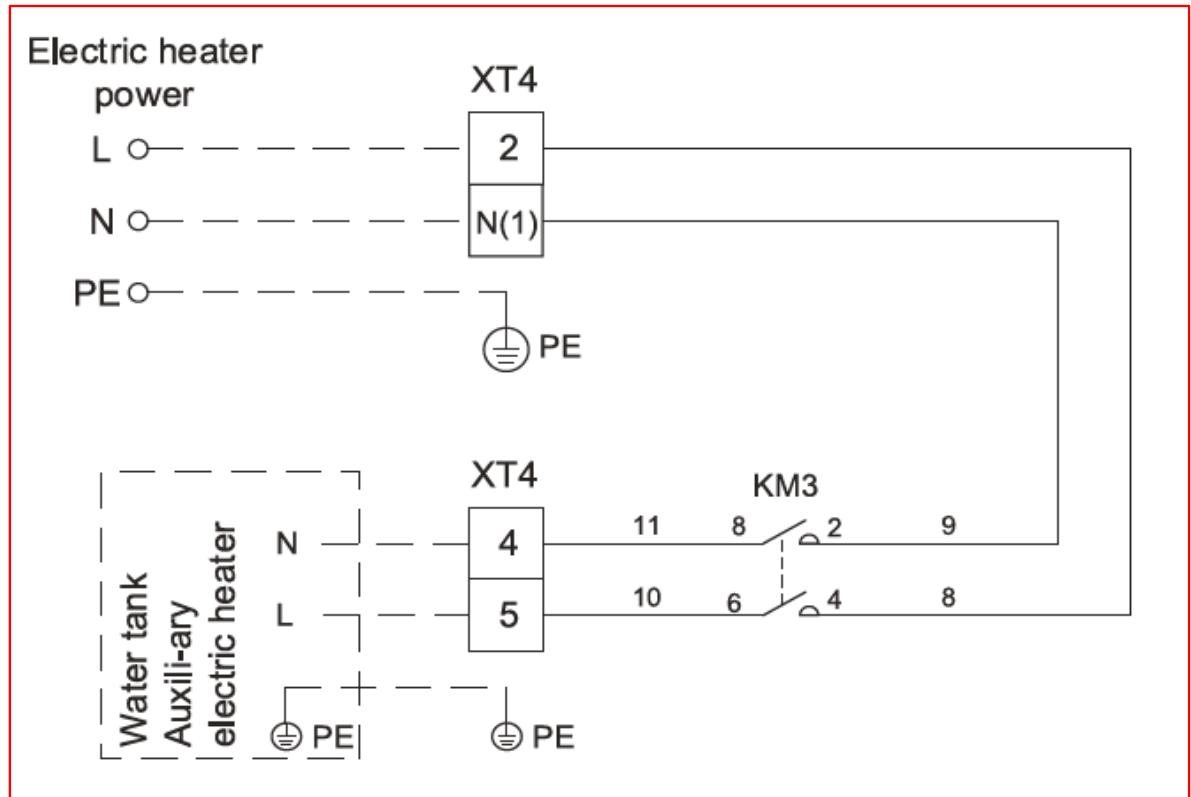
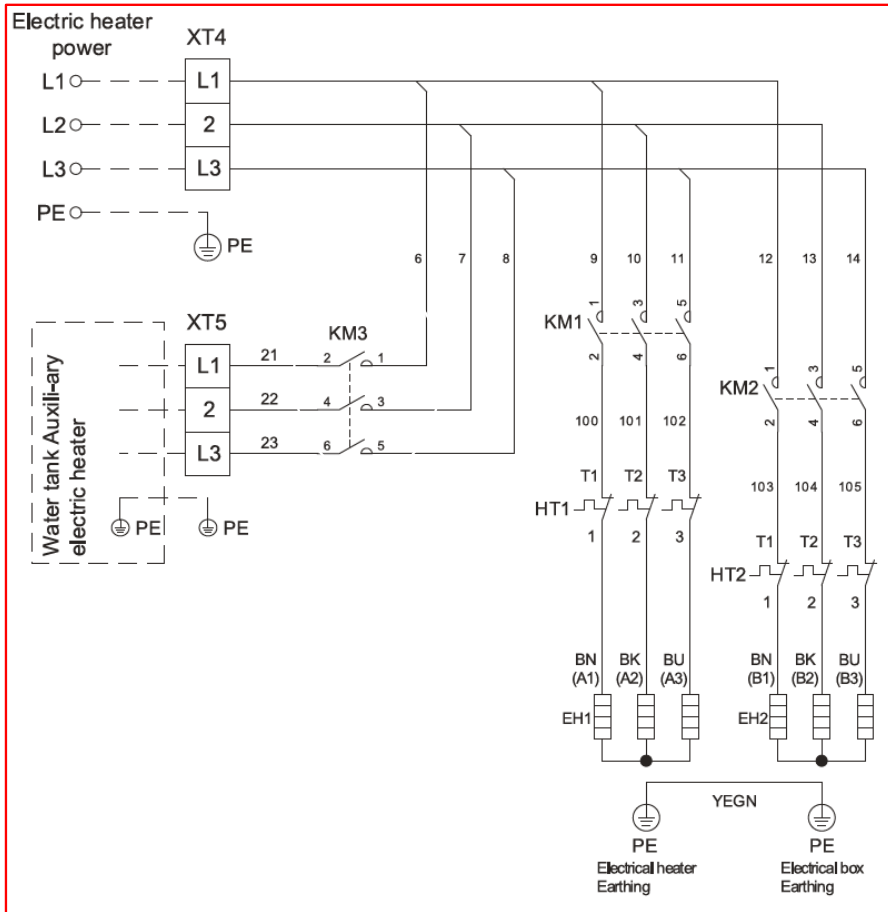

TŌYŌTŌMI

 **Γ.Ε. ΔΗΜΗΤΡΙΟΥ α.ε.ε**

CHAPTER 3

System software characteristics

- Weather Depend Function :
- ✓ Leaving Water Temperature according Ambient Temperature

Display Name	Default
Upper AT-Heat	25
Lower AT-Heat	-20
Upper WT-Heat	55
Lower WT-Heat	40

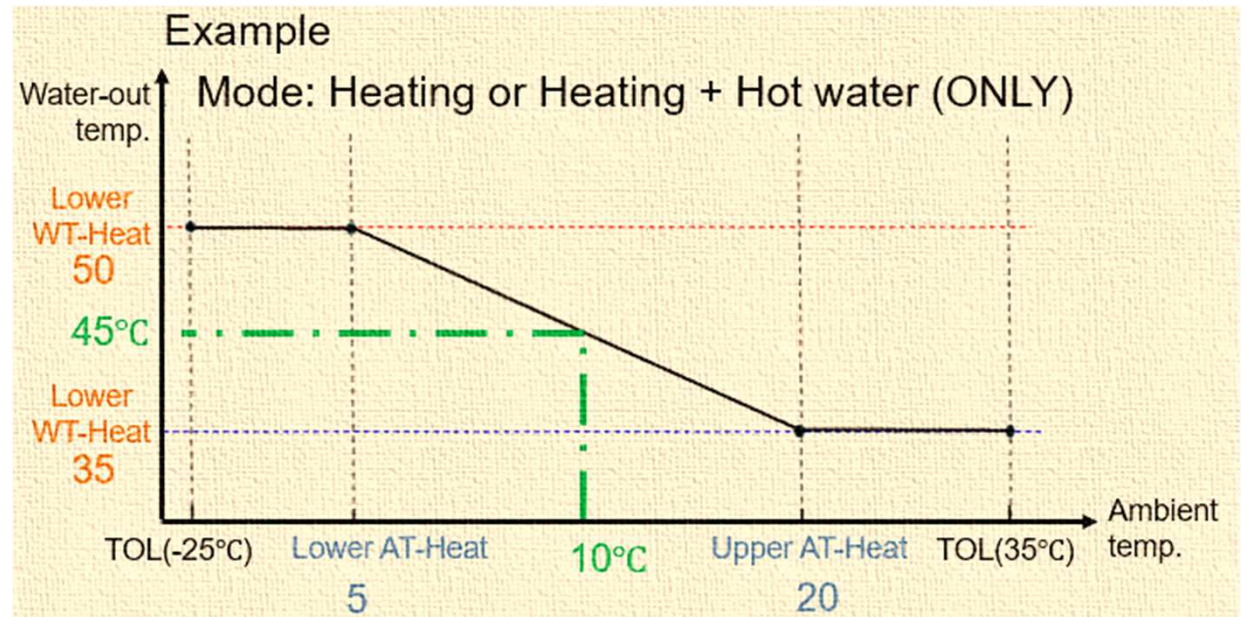

➤ Weather Depend Function :

✓ Room Temperature according Ambient Temperature

TŌYŌTŌMI

Γ.Ε.ΔΗΜΗΤΡΙΟΥ α.ε.ε

Display Name	Default
Upper AT-Heat	7
Lower AT-Heat	25
Upper RT-Heat	24
Lower RT-Heat	18

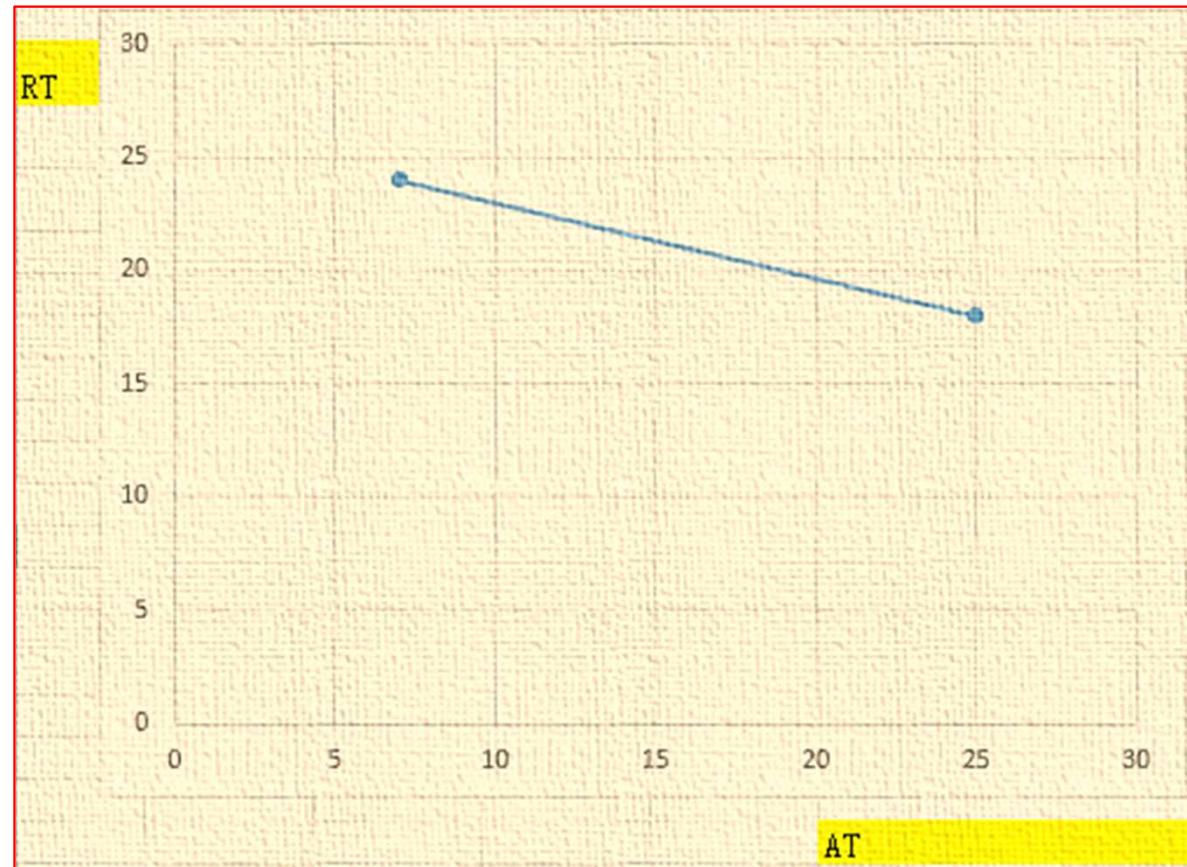

➤ Screeding (Floor Commissioning)

TŌYŌTŌMI

Γ.Ε.ΔΗΜΗΤΡΙΟΥ α.ε.ε

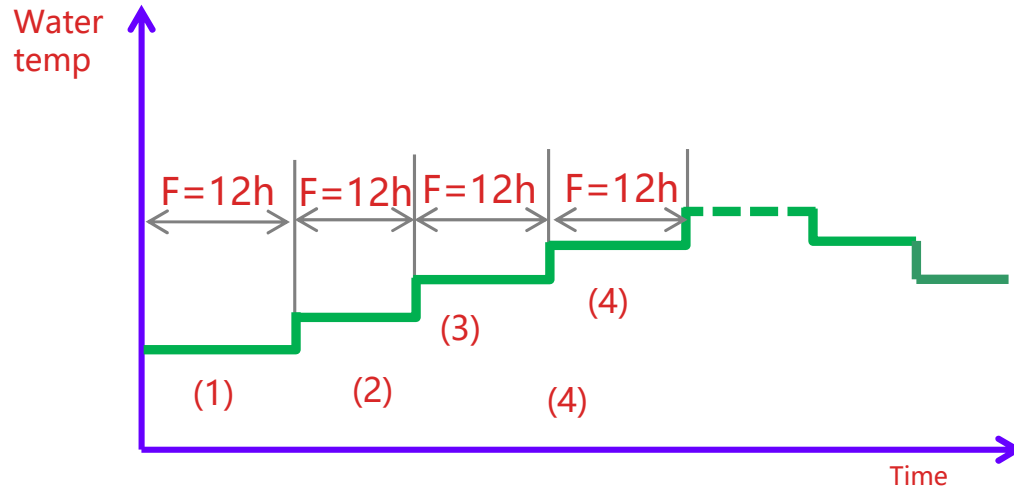

↶
Start

Floor debug: Off

Segments:1

Period 1 temp:25°C

Segment time:0 H

ΔT of segment:5°C

No.	Full Name	Displayed Name	Range	Default	Accuracy
1	Floor debug switch	Floor debug	On/Off	Off	/
2	Quantity of segments	Segments	1~10	1	1
3	Temperature of the first segment	Period 1 temp	25~35°C/ 77~95°F	25°C/ 77°F	1°C
4	Duration of each segment	Segment time	12~72 hours	0	12 hours
5	Temperature difference of each segment	ΔT of segment	2~10°C/ 36~50°F	5°C/ 41°F	1°C

➤ Air removal function H-C & DHW/ Automatic Air Relief!

Air removal	On/Off	Off
-------------	--------	-----

Air removal

Off

Air

Water tank

OK
Cancel

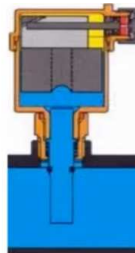
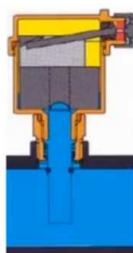

Air: Air Removal for the heating system

Water tank: Air removal DHW

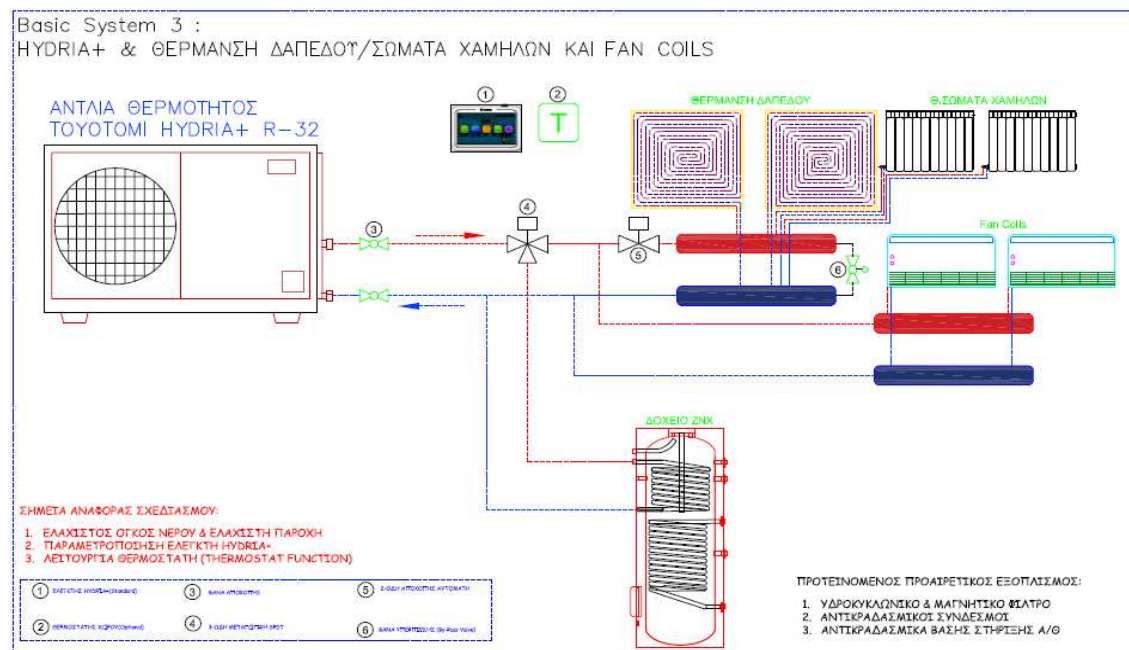

ΤΟΥΤΟΜΙ

Γ.Ε. ΔΗΜΗΤΡΙΟΥ α.ε.ε

➤ View Status Mode Refrigerant & Water Circuits

No	Full Name	Displayed Name	Status	Remarks
1	Status of the compressor	Compressor	On/Off	/
2	Status of the fan	Fan	On/Off	/
3	Status of the unit	Unit status	Cool/Heat/Hot water/Off	"Cool" is unavailable to the heating only unit.
4	Status of the water pump	HP-pump	On/Off	/
5	Status of the water tank heater	Tank heater	On/Off	"NA" for mini chillers
6	Status of the 3-way valve 1	3-way valve 1	NA	/
7	Status of the 3-way valve 2	3-way valve 2	On/Off	"NA" for mini chillers
8	Status of the compressor crankcase heater	Crankc. heater	On/Off	/
9	Status of the heater 1 for the main unit	HP-heater 1	On/Off	/
10	Status of the heater 2 for the main unit	HP-heater 2	On/Off	/
11	Status of the Chassis heater	Chassis heater	On/Off	/
12	Status of the heat exchanger heater	Plate heater	On/Off	/
13	Status for the system defrosting	Defrost	On/Off	/
14	Status of the system oil return	Oil return	On/Off	/
15	Status of the thermostat	Thermostat	Off/Cool/Heat/Hot water/Cool+hot water/Heat+hot water	"Cool" is unavailable to the heating only unit.
16	Status of other thermal source	Other thermal	On/Off	/
17	Status of the 2-way valve	2-way valve	On/Off	/
18	Status of antifreeze	HP-Antifree	On/Off	/
19	Status of the door guard	Gate-Ctrl.	Card in/Card out	/
20	Status of the 4-way valve	4-way valve	On/Off	/
21	Status of disinfection	Disinfection	Off/Running/Done/Fail	/
22	Status of the flow switch	Flow switch	On/Off	/
23	Status of the tank pump	Tank pump	On/Off	/

TŌYŌTŌMI

Γ.Ε. ΔΗΜΗΤΡΙΟΥ α.ε.ε

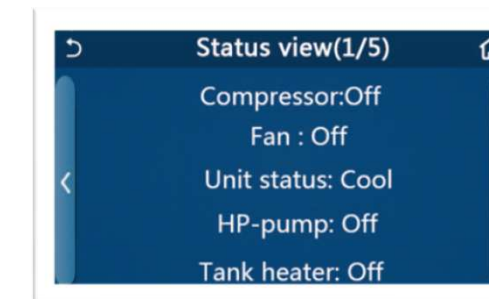
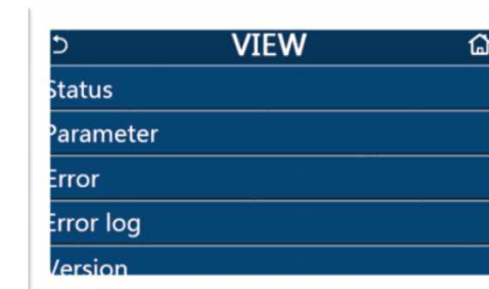

➤ View Parameters Value of Refrigerant & Water Circuits

TŌYŌTŌMI

Γ.Ε. ΔΗΜΗΤΡΙΟΥ α.ε.ε

No.	Full Name	Displayed Name	Remarks
1	Environmental temperature	T-outdoor	/
2	Suction temperature	T-suction	/
3	Discharge temperature	T-discharge	/
4	Defrosting temperature	T-defrost	/
5	Entering water temperature of the plate type heat exchanger	T-water in PE	/
6	Leaving water temperature of the plate type heat exchanger	T-water out PE	/
7	Leaving water temperature of the auxiliary heater	T-optional water Sen.	/
8	Water tank temperature	T-tank ctrl.	/
9	Floor debug target temperature	T-floor debug	/
10	Floor debug runtime	Debug time	/
11	Liquid line temperature	T-liquid pipe	/
12	Vapor line temperature	T-gas pipe	/
13	Economizer inlet temperature	T-economizer in	/
14	Economizer outlet temperature	T-economizer out	/
15	Remote room temperature	T-remote room	"NA" for mini chillers
16	Discharge pressure	Dis. pressure	/
17	Weather-dependent target temperature	T-weather depend	/

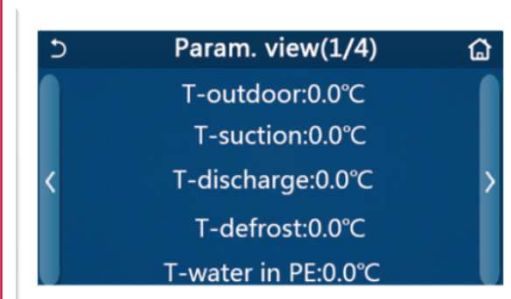
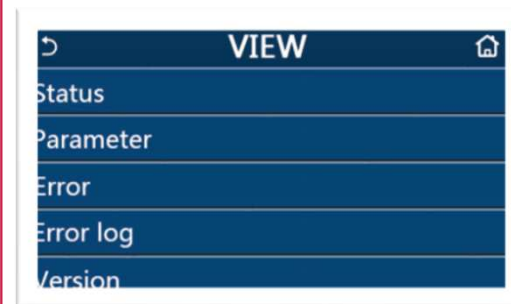

Function menu

No	Item	Range	Default	Remarks
1	Mode	Cool	Heat	1. When the water tank is unavailable, then only "Cool" and "Heat" are available. 2. For the heating only unit, only "Heat" mode, "Hot water", and "Heat + hot water" are available. 3. It is defaulted to be "Heat" for the heat pumps and heating only units and "Cool" for mini chillers.
		Heat		
		Hot water		
		Cool + Hot water		
		Heat + Hot water		
2	Fast hot water	On/Off	Off	1. When the water tank is unavailable, it will be reserved.
3	Cool + hot water	Cool/Hot water	Hot water	1. When the water tank is available, it will be defaulted to be "Hot water"; when unavailable, it will be reserved.
4	Heat + hot water	Heat/Hot water	Hot water	1. When the water tank is available, it will be defaulted to be "Hot water"; when unavailable it will be reserved.
5	Quiet mode	On/Off	Off	/
6	Quiet timer	On/Off	Off	/
7	Weather depend	On/Off	Off	/
8	Weekly timer	On/Off	Off	/
9	Holiday release	On/Off	Off	/
10	Disinfection	On/Off	Off	When the water tank is unavailable, it will be reserved The disinfection date ranges from Monday to Sunday. Saturday is defaulted. 23:00. The disinfection time ranges from 00:00~23:00. 23:00 is defaulted.
11	Clock timer	On/Off	Off	/
12	Temp. timer	On/Off	Off	/
13	Emergen. mode	On/Off	Off	/
14	Holiday mode	On/Off	Off	/
15	Preset mode	On/Off	Off	/
16	Error reset	/	/	Some error can be cleared only when it has been reset manually.
17	WiFi reset			It is used to reset the WiFi.
18	Reset	/	/	It is used to reset all user parameter setting.
19	Child Lock	On/Off	Off	/

TŌYŌTŌMI

 Γ.Ε. ΔΗΜΗΤΡΙΟΥ α.ε.ε

Parameters menu

No	Full Name	Displayed Name	Range	Range	Default	Remarks
			(°C)	(°F)		
1	Leaving water temperature for cooling(T1)	WOT-Cool	7~25°C	45~77°F	18 C /64°F	Unavailable to heating only units
			5~25°C	41~77°F	18 C /64°F	Applicable to the second generation Monobloc series units
2	Leaving water temperature for heating (T2)	WOT-Heat	20~60°C	68~140°F	45°C /113°F	High-temp series units
			20~55°C	68~131°F	45°C/113°F	Normal-temp series units
			20~65°C	68~149°F	45°C/113°F	Applicable to the second generation Monobloc series units
3	Room temperature for cooling (T3)	RT-Cool	18~30°C	64~86°F	24°C/75°F	Unavailable to heating only units
4	Room temperature for heating (T4)	RT-Heat	18~30°C	64~86°F	20°C/68°F	/
5	Water tank temperature(T5)	T-water tank	40~80°C	104~176°F	50°C/122°F	Unavailable to mini chillers
6	Leaving water temperature difference for cooling (Δt_1)	ΔT -Cool	2~10°C	36~50°F	5°C/41°F	Unavailable to mini chillers
7	Leaving water temperature difference for heating (Δt_2)	ΔT -Heat	2~10°C	36~50°F	10°C/50°F	/
8	Leaving water temperature difference for water heating (Δt_3)	ΔT -hot water	2~25°C	36~77°F	5°C/41°F	Unavailable to mini chillers
9	Room temperature control difference (Δt_4)	ΔT -Room temp	1~5°C	34~41°F	2°C/36°F	/

TŌYŌTŌMI

 Γ.Ε. ΔΗΜΗΤΡΙΟΥ α.ε.ε

Commissioning menu

TÖYÖTÖMI

Γ.Ε.ΔΗΜΗΤΡΙΟΥ α.ε.ε

No.	Item	Range	Default	Description
1	Ctrl. state	T-water out/T-room	T-water out	When "Remote sensor" is set to "With", it can be set to "T-room".
2	2-Way valve	Cool 2-Way valve, On/Off	Off	It will decide the status of the 2-way valve under the "Cool" and "Cool + Hot water" modes. Under "Cool" or "Cool + Hot water" mode, the status of the 2-way valve depends on this setting. This setting is unavailable to heating only units.
		Heat 2-Way valve, On/Off	On	It will decide the status of the 2-way valve under the "Heat" and "Heat + Hot water" modes
5	Solar setting	With/Without	Without	When the water tank is unavailable, this setting will be reserved. When it is set to "With", the solar kitting will work on its own. When it is set to "Without", hot water by the solar kitting is unavailable.
6	Water tank	With/Without	Without	Unavailable to mini chillers.
7	Thermostat	Without/Air/Air+ hot water/Air+ hot water2	Without	This setting cannot be interchanged among "Air", "Air+ hot water" and "Air+ hot water2" directly but via "Without" this option.
		On/Off	Off	This setting is available to mini chillers.
8	Other thermal	With/Without	Without	/
9	Optional E-Heater	Off/1/2	Off	/
10	Remote sensor	With/Without	Without	When it set to "Without", and the "Ctrl. state" will be defaulted to be "T-water out".

11	Air removal	On/Off	Off	/
12	Floor debug	On/Off	Off	/
13	Manual defrost	On/Off	Off	/
14	Force mode	Off/Force-cool/Force-heat	Off	"Force-cool" is unavailable to heating only units.
15	Tank heater	Logic 1/Logic 2	Logic 1	1. This setting is allowed when the water tank is available and the unit is OFF. 2. Unavailable to mini chillers.
16	Gate-Ctrl.	On/Off	Off	/
17	C/P limit	Off/Current limit/Power limit	Off	Current limit: it ranges from 0 to 50A and the default is 16A. Power limit: it ranges from 0.0 to 10.0kW and the default is 3.0kW.
18	Address	[1-125] [127-253]	1	/
19	Refri. recovery	On/Off	Off	/
20	Gate-Ctrl memory	On/Off	Off	/
21	3-Way valve1	Without/DHW/AIR	Without	/

No	Full Name	Display Name	Range		Default	Remark
1	T-HP max	T-HP max	40~55°C	104~131°F	50°C/122°F	

Thank you!



Γ.Ε. ΔΗΜΗΤΡΙΟΥ α.ε.ε