

Chiller and Inverter Air/Water heat pumps with axial fans

Controller Manual

Models

- i-290 0121
- i-290 0123
- i-290 0125
- i-290 0127



This manual has been created for informative purpose. The company declines any responsibility for the results of any projecting or any installation based on the explanations and/or on the technical specifications provided in this manual. It is besides forbidden the reproduction under any form of the texts and of the figures contained in this manual. This manual is a translation from the official Italian language version. For reasons of environmental respect the Company will not provide the hard copy in the original language which could be directly requested or downloaded from the Company website at any time. In case of any dispute, the original language manual will be the trusted one. Even partial reproduction PROHIBITED © Copyright - Advantix SpA

01	04-08-2023	M.S.	A.B.	Update e-LITE remote control, b01, b02, b07, C01 descriptions
00	30-01-2023	M.S.	A.B.	First issued
Rev	Date	Edited	Approved	
Catalogo / Catalogue / Katalog / Catalogue				Serie / Series / Serie / Serie / Série
MCO02060120000.01				CONTROL FOR INVERTER AIR/WATER CHILLERS AND HEAT PUMPS WITH AXIAL FANS

The electrical and electronic products and any waste should not be disposed of with normal household waste, but disposed of according to WEEE law in accordance with the directive 2012/19/EU, inquiring thereof at the place of residence or with the retailer in the case where the product is replaced with a similar one.



Contents

1.	HOW TO KEEP THE MANUAL	6
1.1	GRAPHIC SYMBOLS USED IN THE MANUAL	6
2.	PERMITTED USED	6
3.	GENERAL SAFETY GUIDELINES	6
3.1	PERSONAL PROTECTIVE EQUIPMENT	6
3.2	WORKERS' HEALTH AND SAFETY	6
4.	PURPOSE AND CONTENTS OF THE MANUAL	8
5.	USER INTERFACE - CONTROL	8
6.	THERMOSTAT DISPLAY	13
6.1	SETTING THE ROOM THERMOSTAT SETPOINT	13
6.2	OPERATING MODE OF THE THERMOSTAT	14
7.	MENU.....	15
7.1	DIAGNOSTICS.....	15
7.2	ALARMS	15
7.3	ALARM HISTORY	15
7.4	HEAT PUMP SERIAL NUMBER.....	15
7.5	GENERAL SETTINGS.....	15
7.6	INSTALLER MENU.....	15
7.6.1	UNIT SETTINGS	15
7.6.3	HEAT PUMP UPDATE	16
8.	E-LITE INSTALLATION.....	16
9.	E-LITE CONNECTIONS.....	18
9.1	TERMINAL BLOCK	18
10.	EDITING DYNAMIC SET-POINT	19
10.1	SETTINGS FOR STANDARD CLIMATIC CURVES	20
11.	CIRCULATOR.....	20
11.1	CONTINUOUS OPERATION [P03=0] - Default	20
11.2	OPERATION ON CALL FROM TEMPERATURE CONTROLLER [P03=1]	21
11.3	OPERATING ON CALL FROM TEMPERATURE CONTROLLER WITH PERIODIC ACTI- VATION	21
11.4	PROPORTIONAL REGULATION OF THE CIRCULATOR.....	21
11.5	SYSTEM VENTING	21
12.	COMPRESSOR ON/OFF LOGIC	22
13.	REGULATION IN COOLING MODE	22
13.1	REGULATION IN HEAT MODE.....	23
14.	FAN CONTROL OF THE FINNED EXCHANGER	24
15.	CONTROLLER FUNCTIONS	25
15.1	ANTIFREEZE PROTECTION HEATERS (IF KA ACCESSORY IS AVAILABLE).....	25
15.2	ENABLING DOMESTIC HOT WATER PRODUCTION.....	25
15.2.1	MEMORISING THE PROBE IN HEATING MODE	25
15.2.2	HEATING MODE ON DHW STORAGE TANK.....	25
15.2.3	INSUFFICIENT HEAT EXCHANGE IN A DHW SYSTEM	25
15.3	REMOTE-CONTROLLED FUNCTIONS	26
15.3.1	ON/OFF.....	26





15.3.2	SUMMER/WINTER MODE CHANGE	26
15.3.3	ENABLING SG READY FUNCTION.....	26
15.4	SYSTEM WATER REMOTE PROBE.....	27
15.5	FUNCTIONS DIGITAL OUTPUTS CAN BE ACTIVATED.....	27
15.5.1	MACHINE BLOCK.....	27
15.5.2	AUXILIARY RESISTANCES.....	27
15.5.3	BOILER ENABLING	28
15.5.4	ACTIVATION OF INTEGRATION HEATERS AND BOILER IN JOINT OPERATION AND IN SUBSTITUTION OF HEAT PUMP COMPRESSOR	29
15.5.5	SYSTEM SEASON	33
15.5.6	ALARM.....	33
15.5.7	DEFROST.....	33
15.6	DEFROST CYCLE.....	33
15.7	COMPRESSOR CRANKCASE HEATER.....	33
15.8	DOUBLE SET-POINT	33
15.9	MINIMUM HZ FUNCTIONALITY.....	34
15.10	MAXIMUM HZ FUNCTIONALITY	34
15.11	FLOWMETER	34
16.	FUNCTIONS THAT CAN BE ACTIVATED WITH HI-T2 ACCESSORY (OPTIONAL) ...	35
17.	FUNCTIONS THAT CAN BE ACTIVATED WITH G13 MODULE (OPTIONAL).....	35
17.1	I/O RESOURCES OF THE CONTROLLER.....	35
17.2	MANAGEMENT OF SECONDARY CIRCULATOR/RELAUNCH PUMP (WITH ROOM THERMOSTAT).....	36
17.3	MIXER VALVE MANAGEMENT	36
17.3.1	DETERMINATION OF SETPOINT	37
17.3.2	MIXING PUMP.....	37
17.4	SOLAR INTEGRATION MANAGEMENT	37
17.4.1	ACTIVATION OF SOLAR CIRCULATOR.....	37
17.4.2	COLLECTOR PROTECTION	37
17.4.3	COLLECTOR OVERTEMPERATURE ALARM	37
17.4.4	DHW OVERTEMPERATURE ALARM	37
17.4.5	SOLAR EXHAUST VALVE.....	37
17.4.6	DISPOSAL OF SOLAR TANK HEAT	37
17.4.7	ANTIFREEZE.....	37
18.	TABLES OF PERMITTED SETUPS FOR USER AND INSTALLER.....	38
19.	ALARMS.....	43
19.1	[E006] FLOWMETER.....	43
19.2	[E018] HIGH-TEMPERATURE	44
19.3	[E020] INCONGRUENT PRESSURES.....	44
19.4	[E005] ANTIFREEZE	44
19.5	[E611÷E681] PROBE ALARMS	44
19.6	[E801] TIMEOUT INVERTER.....	44
19.7	[E851 ÷E971] INVERTER	44
19.8	[E00] REMOTE ON/OFF (WARNING).....	44
19.9	[E001] HIGH-PRESSURE	44

19.10	[E002] LOW-PRESSURE	44
19.11	[E008] DRIVER LIMITATION	44
19.12	[E041] 4-WAY VALVE.....	44
19.13	POWER FAILURE	44
19.14	UTILITIES BLOCK ALARM TABLE	45
20.	MODBUS VARIABLES	45

1. HOW TO KEEP THE MANUAL

The company reserves the right to modify its products and related manuals without necessarily updating previous versions of the reference material. We also decline any responsibility for possible inaccuracies in the manual if due to printing or transcription errors. The customer shall store any updated copy of the manual or parts of it delivered by the manufacturer as an attachment to this manual. The company is available to give any detailed information about this manual and to give information regarding the use and the maintenance of its own units.

1.1 GRAPHIC SYMBOLS USED IN THE MANUAL

	Indicates prohibited operations.
	Indicates potentially hazardous situation for people and/or the proper functioning of the unit.
	Hazardous electrical voltage - Electrocutation hazard.
	Indicates important information that the operator has to follow in order to guarantee the correct operation of the unit in complete safety. Also indicates some general information.

2. PERMITTED USED

- The company excludes any contractual and extra contractual liability for damage caused to persons, animals or objects, by incorrect installation, setting and maintenance, improper use of the equipment, and the partial or superficial reading of the information contained in this manual.
- These units are built for the heating and/or cooling of water. Any other use not expressly authorised by the manufacturer is considered improper and therefore not allowed.
- All the work must be executed by skilled and qualified personnel, competent on the existing regulations in country of installation.
- This appliance is intended to be used by expert or trained operators in shops, light industry and in factories, or for commercial use by non-expert personnel.
- The appliance may be used by children at least 8 years old and by persons with reduced physical, sensory or mental capabilities or without experience or the necessary knowledge as long as they are supervised or after they themselves have received instructions on the safe use of the appliance and understand the relevant dangers. Children must not play with the appliance. The cleaning and maintenance which the user is expected to carry out on the unit cannot be done by children without supervision.

3. GENERAL SAFETY GUIDELINES



Before starting any type of operation on the unit, every user and operator must have perfect knowledge of operation of the machine and of its controls and have read and understood all of the information in this manual and in the user-installer manual.

3.1 PERSONAL PROTECTIVE EQUIPMENT

Refer to the user-installer manual which accompanies the unit.

3.2 WORKERS' HEALTH AND SAFETY

Refer to the user-installer manual which accompanies the unit.

	IT IS PROHIBITED:
	To remove and/or to tamper with any safety device.
	For unauthorised personnel to access the electric panel.
	To work on live systems.
	To touch the systems if not authorised to do so.
	To allow children or unassisted disabled persons to use the appliance.
	To touch the appliance when barefoot or parts of the body are wet or damp.
	To perform any cleaning operation when the master switch is 'ON'.
	To pull, detach or twist the appliance's electric cables.
	To step on, sit down on and/or place any type of object on the appliance.
	To spray or pour water directly on the unit.
	To dispose of, abandon or leave within reach of children packaging materials (cardboard, staples, plastic bags, etc.) as they may represent a hazard for the environment and one's life. To tamper with or replace parts of the unit without the specific consent of the manufacturer. The manufacturer shall have no responsibility whatsoever in case of unauthorised operations.
	
Refer to the user-installer manual which accompanies the unit before proceeding.	
All the operation described below must be done by QUALIFIED PERSONNEL ONLY .	
The electrical wiring to the terminal blocks has to be done only by qualified personnel.	
Any routine and/or extraordinary maintenance operation must be carried out with the machine stopped and disconnected.	
Do not place your hands or introduce screwdrivers, spanners or any other tools on moving parts.	
The machine operator and maintenance personnel must receive suitable training for the performance of their tasks in safety.	
Only authorised personnel are allowed to have access to the electric panel.	
Operators must know how to use personal protective equipment and the accident-prevention rules of national and international laws and regulations.	
The operator's workplace has to be kept clean, tidy and clear of objects that may hinder free movement. Appropriate lighting of the work place shall be provided so as to allow the operator to carry out the required operations safely. Poor or excessive lighting can cause risks.	
Ensure that work places are always adequately ventilated and that the extraction systems are working, in good condition and in compliance with the requirements of the laws in force.	
Not all of the configurations described can be activated and/or modified at the same time.	
Values other than the default values can jeopardise proper operation of the unit. For further information regarding the value to set, you can refer directly to ADVANTIX S.p.a.	
The company excludes any contractual and extra contractual liability for damage caused to persons, animals or objects, by incorrect installation, setting and maintenance, improper use of the equipment, and the partial or superficial reading of the information contained in this manual.	

	The power supply has to respect the limits shown on the unit's technical label: failing this, the warranty shall expire immediately. Before beginning any type of operation, make sure that power is disconnected.
	Connect the conductors in order: phase, neutral and earth.
	Dimensioning of the power cables must take into consideration the TECHNICAL DATA provided in the user-installer manual accompanying the unit. Also consider any auxiliary heating devices.
	Effective earthing is mandatory; the manufacturer is not responsible for damage caused in its absence.
	When undergoing maintenance, the unit must be disconnected from the power supply, and it must be unplugged in such a way that the operator can verify from wherever he accesses that the plug remains disconnected.
	Use cables that meet the regulations in force in the different countries.
	After the unit has been running for 10 minutes, make sure that the screws on the power terminal block remain secured.

	Install upstream of each unit a suitable QF protective device and power disconnecter, with delayed characteristic curve, with at least 3 mm contact opening and adequate breaking capacity and residual current protection. The size of the circuit breaker must comply with absorption of the unit. See the TECHNICAL DATA in the user-installer manual which accompanies the unit. Also consider any auxiliary heating devices.
	Before performing any operations on the electric panel, IT IS MANDATORY:
	To switch off the unit from the control panel ("OFF" displayed).
	To place the general residual current device QF at "OFF".
	To wait 15 seconds before accessing the electric panel.
	To check the grounding before performing any operation.
	To remain well isolated from the ground, with dry hands and feet, or using insulated platforms and gloves.
To keep foreign materials away from the system.	

4. PURPOSE AND CONTENTS OF THE MANUAL

The manual is intended to provide the essential information to configure the controller of the units.

It is addressed to the installer and operators of the appliance and it enables them to use the equipment efficiently, even if they do not have any previous specific knowledge of it.

Not all of the functions described can be activated and/or selected at the same time. Contact our headquarters for further information.

The manual describes the machine at the moment it was sold. It must therefore be considered adequate with respect to the state-of-the-art in terms of potentiality, ergonomics, safety and functionality.

The company also performs technological upgrades and does not consider itself obliged to update the manuals of previous machine versions which could even be incompatible. Therefore make sure to use the supplied manual for the installed . Contact our headquarters in case of updates or doubts.













The user is recommended to follow the instructions contained in this booklet, especially those concerning safety and routine maintenance.

5. USER INTERFACE - CONTROL

Included with each unit is the e-Lite remote keypad.

The following list represents the present icons, and their meaning:

ICON	DESCRIPTION	NOTE
	Heat pump screen	Opens the heat pump screen (home screen).
	DHW screen	Opens the domestic hot water screen.
	Thermostat screen	Opens the thermostat screen.
	Menu	Opens the menu screen.
	Cooling	Heat pump in system cooling.

ICON	DESCRIPTION	NOTE
	Heating	Heat pump in heating system.
	Domestic hot water	Heat pump in domestic hot water.
	Set-point Comfort	Comfort set-point enabled.
	Set-point Economy	Set-point economy enabled.
	Compressor	White symbol, steady: compressor Off. White symbol, flashing: compressor on call. Blue symbol, fixed: compressor On.
	Circulator	White symbol: circulator Off. Blue symbol: circulator On.
	Alarm	List of active alarms.
	ON/OFF	Switches the heat pump on or off.
	Chronothermostat	Enables or disables the chronothermostat.
	Defrosting	Steady symbol, if the heat pump is in defrost mode. Flashing symbol, if the heat pump is in defrost call.
	Antifreeze resistance	.The antifreeze resistor is in operation.
	Anti-legionella	Fixed symbol if the heat pump is running the anti-legionella cycle. Flashing symbol if the anti-legionella cycle has not been completed.

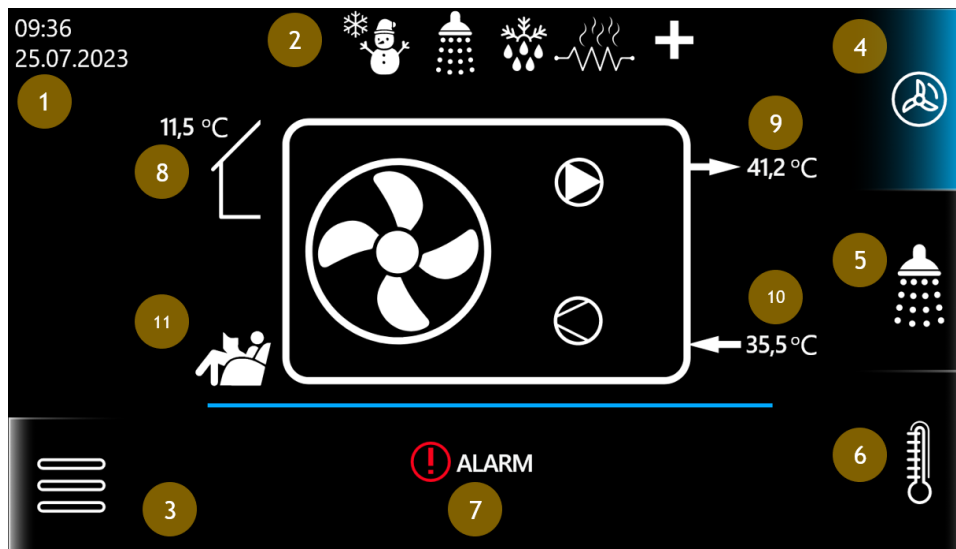

Heat pump screen, main control screen.



Number	Description
1	Date and time
2	The message 'NO COMMUNICATION' is displayed if there is no communication between main control and e-Lite remote control (in this case, check that the connection is correct)
3	Main menu
4	Heat pump screen
5	DHW screen
6	Thermostat screen
7	Active alarms and forcing
8	Outside temperature
9	Water flow temperature
10	Water inlet temperature
11	Current heat pump status

The possible states of the heat pump are as follows:

ICON	DESCRIPTION
	Manually enabled comfort set-point.
	Manually enabled economy set-point.
	Heat pump in manual stand-by.
	Chronothermostat enabled, with comfort set-point active.
	Chronothermostat enabled, with economy set-point active.

ICON	DESCRIPTION
	Chronothermostat enabled, heat pump in stand-by mode.
	Set-point comfort enabled by forcing "digital input" (see heat pump MCO, "secondary set-point from digital input").
	Set-point economy enabled by forcing "digital input" (see heat pump MCO, "Secondary set-point from digital input").

If you tap on the symbol , the operating modes of the heat pump are displayed:

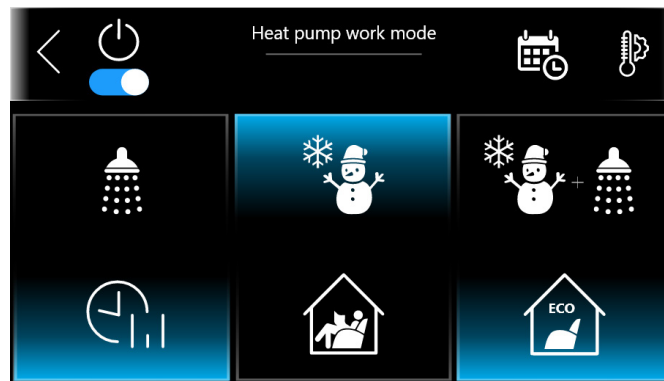

If you tap on the symbol , the setpoint setting tab is displayed:



If you tap on the symbol , the mode selection and timing screen is displayed:

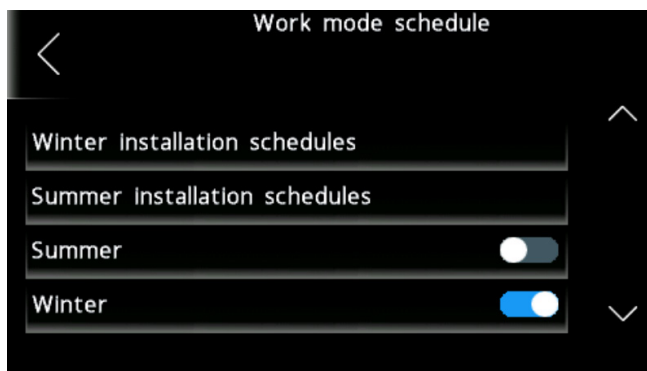

If you tap on the season selection switch, the selected season is active for the heat pump and thermostat function.
 If you tap the summer programming chrono switch, the chrono programming screen is displayed:

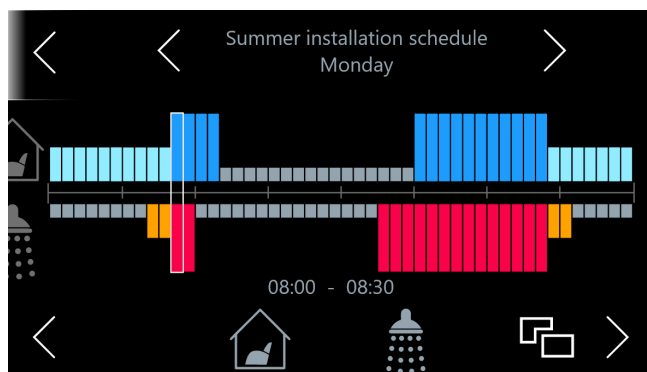

The strip represents the day, which is divided into 48 parts. The duration of each part is 30 minutes. You can change the day with the > and < arrows.

The low blue strip represents the enablement of the cooling mode, with Economy setpoint.

The low orange strip represents the enablement of the cooling mode, with Comfort setpoint.

The low orange strip represents the enabling of the heating mode, with Economy setpoint.

The high red stripe represents the enabling of the heating mode, with Comfort setpoint.

The grey stripe represents disabled mode.

It is possible to scroll left or right, modifying each slightest division, by enabling the following symbols:

ICON	DESCRIPTION
	Heat pump (water outlet configuration) OFF. By scrolling left and right with the arrows, the water outlet configuration of the heat pump system is disabled.
	Heat pump (water outlet configuration). By scrolling left and right with the arrows, the water outlet configuration of the system is enabled, in cooling mode with the Comfort set-point.
	Heat pump (water outlet configuration). Scrolling left and right with the arrows enables the configuration of the system water outlet in cooling mode with the Economy set-point.
	Heat pump (water outlet configuration). Scrolling left and right with the arrows enables the configuration of the system water outlet in heating mode with the Comfort set-point.
	Heat pump (water outlet configuration). Scrolling left and right with the arrows, enables the configuration of the system water outlet in heating mode with the Economy set-point.

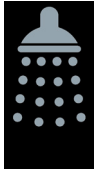
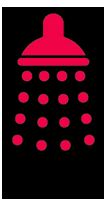
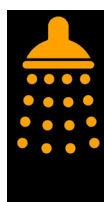
ICON	DESCRIPTION
	Heat pump, DHW OFF. Scrolling left and right with the arrows, the DHW configuration of the heat pump is set to OFF.
	Heat pump, DHW configuration. Scrolling left and right with the arrows enables the configuration of the system water outlet in cooling mode with the Comfort set-point.
	Heat pump (water outlet configuration). Scrolling left and right with the arrows enables the configuration of the system water outlet in cooling mode with the Economy set-point.

6. THERMOSTAT DISPLAY

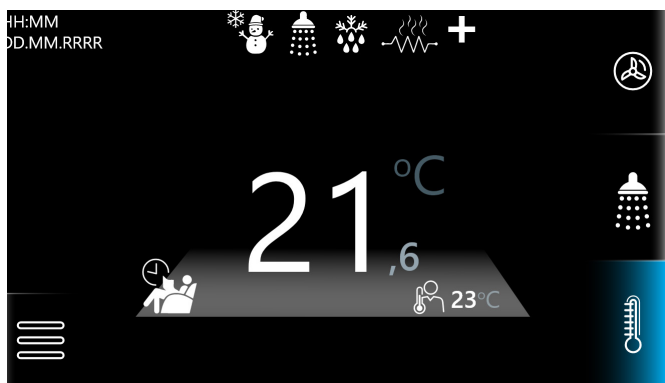

Thermostat function, which uses the e-LITE, internal probe to measure the room temperature. By activating this function, the internal probe will be used to switch the heat pump on or off. The thermostat call will be sent to the heat pump if:

- The unit is in cooling or heating mode
- The internal temperature probe has not reached the set-point

NOTE:
In the centre of the screen, the temperature measured by the internal probe is displayed. At the bottom right, the current setpoint value is displayed.

6.1 SETTING THE ROOM THERMOSTAT SETPOINT

Tapping on the measured temperature displays the setpoint change screen:



Tapping on the gear symbol, the thermostat settings are displayed:

Function	Description	Range
Winter comfort	Comfort setpoint for heating operation mode	20°C / 78°C
Winter economy	Economy setpoint for heating operation mode	20°C / 78°C
Summer comfort	Comfort setpoint for cooling operation mode	5°C / 20°C
Summer economy	Economy setpoint for cooling operation mode	5°C / 20°C

Function	Description	Range
Thermostat hysteresis	After the room setpoint has been reached, the room call will be sent to the heat pump again, when the room temperature: in heating mode: falls lower than 'room setpoint - thermostat hysteresis'. In cooling mode: increases over 'air setpoint + thermostat hysteresis'.	0°C / 5°C
Correction of displayed temperature	Correction of temperature detected by internal probe	-5°C / +5°C

6.2 OPERATING MODE OF THE THERMOSTAT

On the thermostat's main screen, tapping on the status symbol in the bottom left-hand corner displays the thermostat's operating modes:

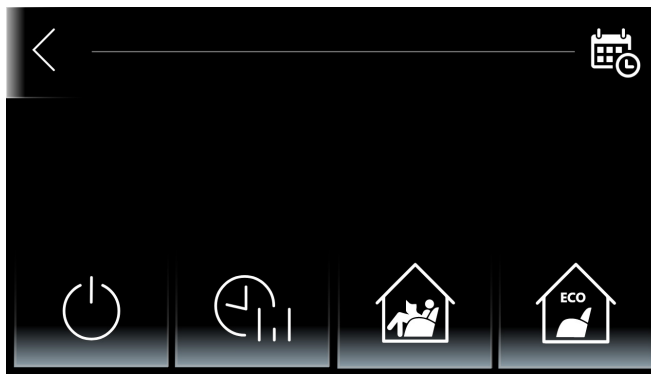

ICON	DESCRIPTION	NOTE
	ON/OFF	Activates/deactivates the thermostat function
	Chrono programming	Enables or disables chrono programming
	Comfort Setpoint	<ul style="list-style-type: none"> Switches to thermostat comfort setpoint, manual mode Displayed if the chrono thermostat is active and in comfort mode
	Economy Setpoint	<ul style="list-style-type: none"> Switches to thermostat economy setpoint, manual mode Displayed if the chrono thermostat is active and in economy mode



Tapping on the symbol , the operating season and the thermostat timer are displayed:

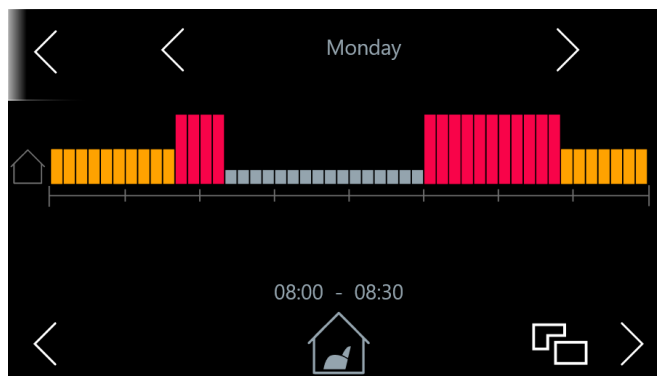

The strip represents the day, which is divided into 48 parts. The duration of each part is 30 minutes. It is possible to change the day with the > and < arrows.

The low blue stripe represents cooling operation, Economy setpoint.





The low blue stripe represents cooling operation, setpoint Comfort.

The low orange stripe represents heating operation, Economy setpoint.

The low red stripe represents heating operation, setpoint Comfort.

Grey stripe, represents disabled mode.

The "copy symbol" , allows to select the days of the week, where we want to have the same program as the day shown. Scrolling to the left and right, you can edit each smallest division, enabling the following symbols:

ICON	DESCRIPTION
	Heat pump (water outlet configuration) OFF. Scrolling left and right with the arrows, the water outlet configuration of the heat pump system is disabled.
	Heat pump (water outlet configuration). Scrolling left and right with the arrows, the water outlet configuration of the system is enabled, in cooling mode with the Comfort set-point.
	Heat pump (water outlet configuration). Scrolling left and right with the arrows enables the water outlet configuration of the system, in cooling mode with the Economy set-point.
	Heat pump (water outlet configuration). Scrolling left and right with the arrows enables the configuration of the system water outlet in heating mode with the Comfort set-point.
	Heat pump (water outlet configuration). Scrolling left and right with the arrows enables the configuration of the system water outlet in heating mode with the Economy set-point.

7. MENU

From the main screen, tapping on the menu symbol (bottom left) displays the main menu:

7.1 DIAGNOSTICS

In this area, input and output values and heat pump counters are displayed.

NOTE:

The firmware version of the main control board and the e-Lite can also be found here.

7.2 ALARMS

List of active alarms.

Tapping on the reset symbol , will reset all alarms that are no longer active.

7.3 ALARM HISTORY

Alarm history, with date and time of alarm occurrence and stop.

7.4 HEAT PUMP SERIAL NUMBER

Heat pump serial number.

7.5 GENERAL SETTINGS

- Date and time
- Language
- Day brightness: Brightness Day: percentage of display brightness while using the e-LITE.
- Night Brightness: percentage of display brightness when the e-LITE is in stand-by mode.
- Touch-screen sound: enable or disable tap sound.

7.6 INSTALLER MENU

This menu provides access to heat pump configurations and functions.

This menu provides access to heat pump configurations and functions.

User password: 0000.

Depending on the password level entered, different menus are displayed.

7.6.1 UNIT SETTINGS

The parameters displayed depend on the password set:

This menu gives access to all machine parameters.

The parameters are collected in groups, each group is identified by a three-digit code, while the index of each parameter is preceded by a letter.

DESCRIPTION	GROUP IDENTIFICATION CODE	PARAMETER INDEX	VISIBILITY
Local water set-points (in cooling and heating, eco and normal). When the e-LITE remote control is connected to the heat pump, reference is not made to these set-points, but to those on page	Set	User	---
Configuration	CnF	H01-	Installer
Compressor	CP	C01-	Installer
Alarms	ALL	A01-	Installer
Adjustment	rE	b01-	Installer
Pump	PUP	P01-	Installer
Electrical heaters	Fro	r01-	Installer
Defrosting	dFr	d01-	Installer
Hz min / max	LbH	L0-	Installer
*Solar	SUn	S01-	Installer
*Mixing valve	rAD	i01-	Installer

The PSS menu is accessed to enter the maintainer password and to enable higher privilege access. Once entered, the duration of the password is one hour, or until the control is switched off.

7.6.2 FORCING



This menu is protected by an installer password.

- Remote panel alarm history reset: resets the e-LITE alarm history
- Main control alarm history reset: resets the main control alarm history
- Reboot main control: restarts the main control of the heat pump (only enabled if the heat pump is in stand-by)
- Defrost: forces a manual defrost (see conditions to enable defrost, in heat pump MCO)
- Venting system: activation of the circulator to force venting of the system. With a tap, the function is activated. With the function active, a new tap on it disables it. Note that the command is only accepted if the heat pump is in the OFF state. The heat pump suspends this function if the operating mode changes from OFF to another mode, even if the function time has not expired.
- Circulator forcing: This function is used to manually force the circulation circulator to run at 100% for 1 hour. A tap on this function will activate it. With the function active, a new tap on it disables it. Note that this command is only accepted if the heat pump is in the OFF state. The heat pump will suspend this function if the operating mode is changed from OFF to another mode, even if the function time has not expired.
- Forcing solar circulator: This function is used to manually enable the solar circulator. A tap on this function will enable it. With the function active, a new tap on it disables it. Note that this command is only accepted if the heat pump is in the OFF state. The heat pump will suspend this function if the operating mode is changed from OFF to another mode, even if the function time has not expired.

NOTE:

The main screen will be displayed when a forcing is activated.

7.6.3 HEAT PUMP UPDATE



This menu is protected by an installer password.

- FW UPDATE: Main control board firmware update
- PARAMETERS UPDATE: Main control board parameter update
- PARAMETERS EXPORT: exports parameters and alarm history of main control.
- PROGRESS: progress status.

8. E-LITE INSTALLATION

The control is intended to be installed on a wall or placed on a flat surface. The panel cannot be used under conditions of water vapour condensation and must be protected against water. It must be installed at a height that allows it to be used comfortably, typically 1.5 metres above the floor.

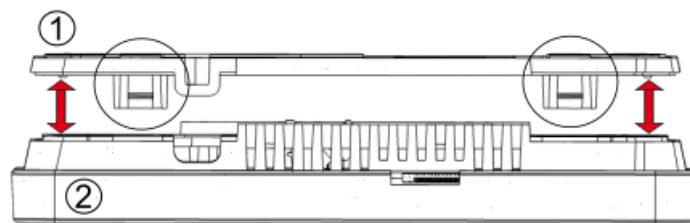

In order to reduce the interference of temperature measurement by the control panel, avoid sunny places with poor air circulation, close to heating devices and placed directly at doors and windows (generally at least 200 mm from the edge of the door).

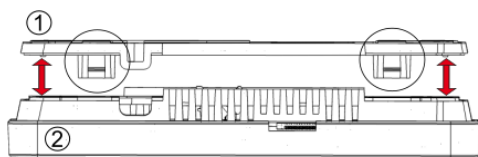

The control panel must be installed according to the instructions below. Disconnect the installation frame (1) from the back of the room thermostat housing (2). The frame is secured to the panel housing with latches. Use a flat screwdriver to detach the frame.

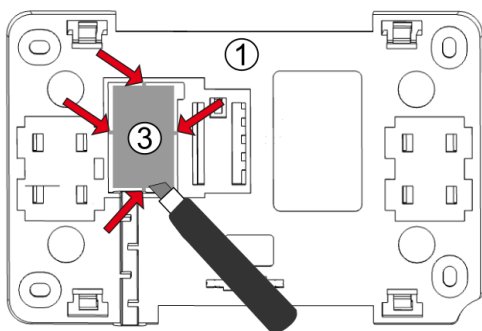

Using a sharp tool, cut holes in four places in the cover (3) for the screw terminals.

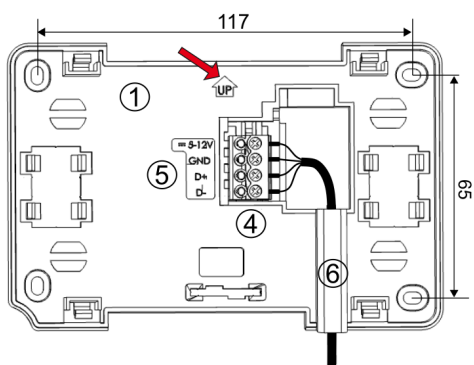

Connect the wires of a transmission cable, connecting the control panel with the heat pump, to the screw terminal (4) as described on the plate (5). The control panel of the cable connection with the heat pump can be recessed in the wall or can slide on its surface - in this case the cable must be additionally positioned in the cable channel (6) of the installation frame. The cable connection panel with the heat pump may not be routed together with the building network cables. The cable must not be routed close to devices that emit a strong electromagnetic field.

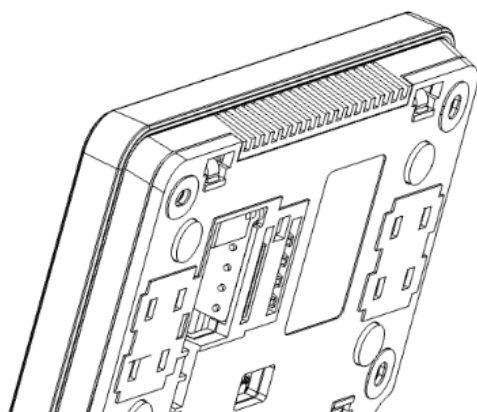

Drill the holes in the wall and use screws (max. \varnothing 3 mm) to fix the installation frame at the selected location on the wall. The distance of the holes can be determined by positioning the frame on the wall. Then fix the panel to the installation frame using the clips.

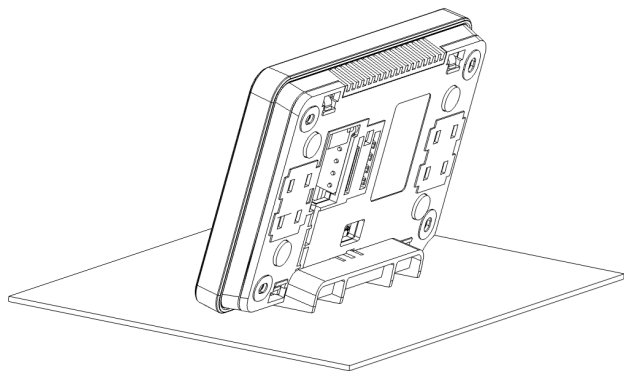

Use a dedicated stand to place the control panel on a flat surface.

9. E-LITE CONNECTIONS

Two connection cables are required between chiller unit or heat pump and e-Lite remote control:

- 5X1mm² twisted and shielded cable for Modbus communication D+/D-, PE, and 12Vdc power supply, which is included in the box.

NB: The shield of the cable must be connected to PE in both of its ends.

DESCRIPTION	e-LITE TERMINALS	CHILLER/HEAT PUMP TERMINALS (see documentation relating to the heat pump)	12Vdc POWER SUPPLY	NOTES
POWER SUPPLY	VCC		SEC, red, +	SHIELDED AND TWISTED CABLE
	GND		SEC, black, -	
COMMUNICATION	D+	1A (i-290)		
	D-	1B (i-290)		
SHIELDING		PE clamp of the User terminal block		

9.1 TERMINAL BLOCK

See relevant chapter in the i-290 User-Installer Manual.

TERMINAL BLOCK	CONNECTION	TYPE
PE	Connect the earthing cable	Input for 1-Ph/N/PE power supply, 230 V, 50 Hz. (only for sizes 0106/0109/0112)
N	Connect the neutral cable from mains	
L	Connect phase L1 cable from mains	
L2	Connect phase L2 cable from mains	Input for 3-Ph/N/PE power supply, 400 Vac, 50 Hz. (only for sizes 0115 / 0118)
L3	Connect phase L3 cable from mains	
1A	Primary channel Modbus RTU + remote keyboard signal connection	Modbus communication for remote keyboard i-CR For signal use shielded twisted pair cable 3 x 0.75 mm ² (1A = pin 7, 1B = pin 8, 1C = pin 9)
1B	Primary channel Modbus RTU - remote keyboard signal connection	
1C	Primary channel Modbus GND remote keyboard signal connection	
12 Vac	Remote keyboard power supply (12 Vac, 50 Hz, 500 mA)	For power supply use 2 x 1 mm ² cable (connect to pins 12 and 13)
12 Vac	Remote keyboard power supply (12 Vac, 50 Hz, 500 mA)	
2A	Secondary channel Modbus RTU + signal connection GI3 module or remote supervision	Connection of GI3 module, if fitted as an accessory. Alternatively connection of Modbus RTU RS 485 communication for remote supervision, if CM accessory present. The GI3 module and CM supervision cannot be connected at the same time.
2B	Secondary channel Modbus RTU - signal connection GI3 module or remote supervision	
2C	Secondary channel Modbus GND signal connection GI3 module or remote supervision	
ID2	Remote summer/winter mode change input (to activate the function see relevant section in the MCO manual)	Voltage-free digital input

TERMINAL BLOCK	CONNECTION	TYPE
ID3	Remote on/off input (closed = machine on / open = machine off)	Voltage-free digital input
A16	DHW probe (to activate the function see the relevant section in the MCO manual)	Analogue input
A17	System remote probe (to activate the function see relevant section in the MCO manual)	Analogue input
A18	Double set point (to activate the function see the relevant section in the MCO manual)	Digital input
DO3 (*)	System integration resistance	Single-phase voltage output 230 Vac, 50 Hz, maximum current 300 mA (AC1)
DO6 (*)	Valve outlet sanitary hot water	Single-phase voltage output 230 Vac, 50 Hz, maximum current 300 mA (AC1)
DO7 (*)	Valve outlet second set point	Single-phase voltage output 230 Vac, 50 Hz, maximum current 300 mA (AC1)

(*) if used, it is recommended to drive a relay coil or contactor with the voltage output to manage the resource.

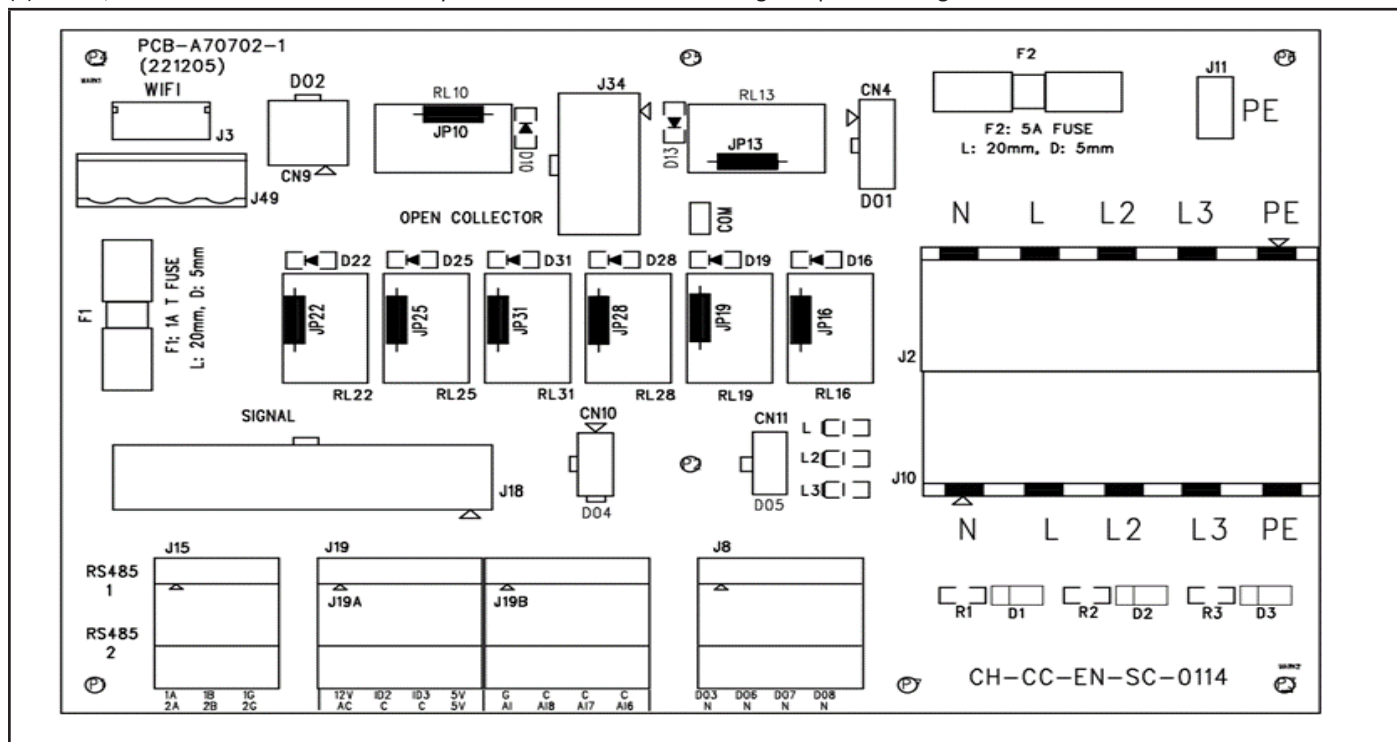

10. EDITING DYNAMIC SET-POINT

The regulator allows you to modify the set-point by adding up the value according to the temperature of the outdoor air probe. To use this function, edit the values from parameter **b08** to **b14** following the information below (edited by the installer).

Parameters of regulator **PAR** -> **rE**

- **b08** enable = 1/disable=0 dynamic set-point.
- **b09** = maximum cooling offset.
- **b10** = maximum heating offset.
- **b11** = Cooling outdoor temperature setting.
- **b12** = Heating outdoor temperature setting.
- **b13** = Cooling temperature delta.
- **b14** = Heating temperature delta.

Edit the setpoint depending on the outdoor temperature:

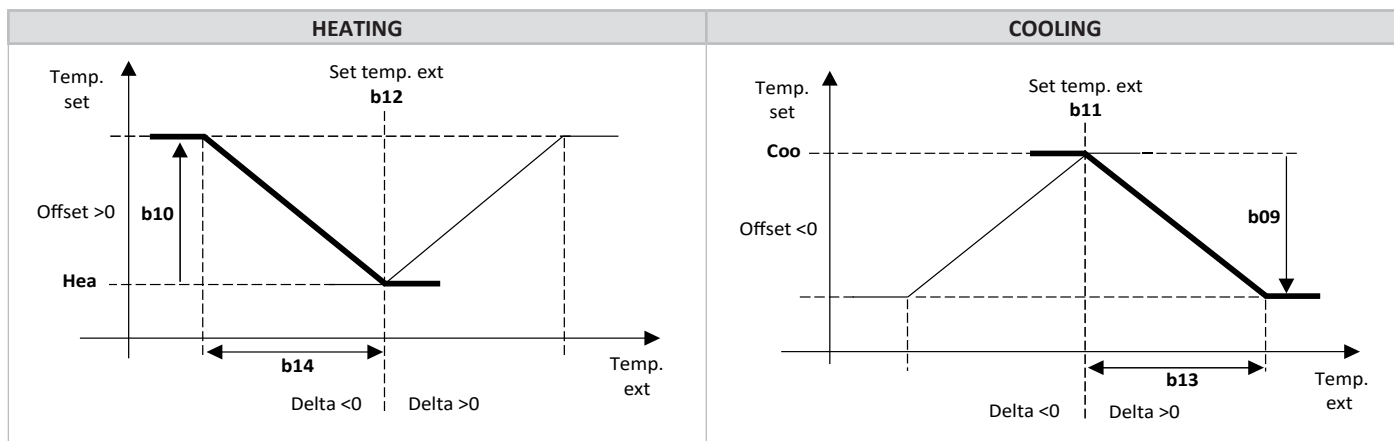

10.1 SETTINGS FOR STANDARD CLIMATIC CURVES

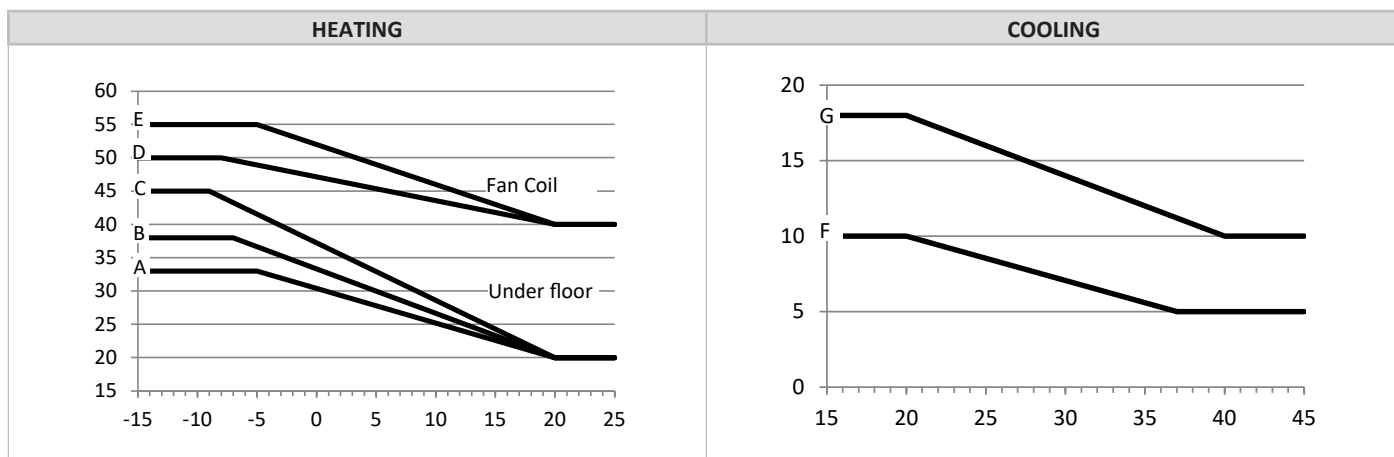

CURVE	Setpoint Heat	Setpoint Cool	b08	B09	b10	B11	b12	B13	b14
A	20°C	--	1	--	13°C	--	20°C	--	-25°C
B	20°C	--	1	--	18°C	--	20°C	--	-27°C
C	20°C	--	1	--	25°C	--	20°C	--	-29°C
D	40°C	--	1	--	10°C	--	20°C	--	-28°C
E	40°C	--	1	--	15°C	--	20°C	--	-25°C
F	--	5°C	1	5°C	--	37°C	--	-17°C	--
G	--	10°C	1	8°C	--	40°C	--	-20°C	--

11. CIRCULATOR

The circulator of the heat pump can be set in the following operating modes:

- operation on call by temperature controller
- operating on call by temperature controller with periodic activation;
- continuous operation (default);

The circulator is switched off immediately if:

- There is a manual reset pump block alarm, including the flow switch alarm;
- With remote input in standby or off, the pump (if running) is always switched off with a delay equal to P02 in tenths of a minute (default P02=2)

The circulator can be configured with P03 to operate independently from the compressor or on call.

0=continuous operation in heating/cooling mode(default P03=0)

1=operating on call by temperature controller

Note: with active no-flow alarm in automatic reset, the circulator is on even if the compressor is off. The circulator is always on when the antifreeze heaters are running and if operation of the hydraulic pump in antifreeze is enabled. Antifreeze operation is enabled if the regulation temperature drops below P04 °C (default 5°C), and disables if the regulation temperature rises above P04+P05 °C (Default value P05=2,0°C).

Note: It is possible to change the maximum and minimum speed of the circulator by adjusting parameters P07 and P08 respectively.

11.1 CONTINUOUS OPERATION [P03=0] - Default

The circulator is only off with the unit OFF, in all other cases it is always on.

11.2 OPERATION ON CALL FROM TEMPERATURE CONTROLLER [P03=1]

In this operating mode, the circulator is active on demand by the temperature controller, after a delay time of **P01** seconds (default **P01=30**) from when the pump switched on, the compressor switches on as well.

Whereas when switching off, the pump is deactivated after a delay time of **P02** minutes (default **P02=2**) from when the compressor switches off. With automatic reset flow switch alarm triggered, the circulator is on even if the compressor is off.

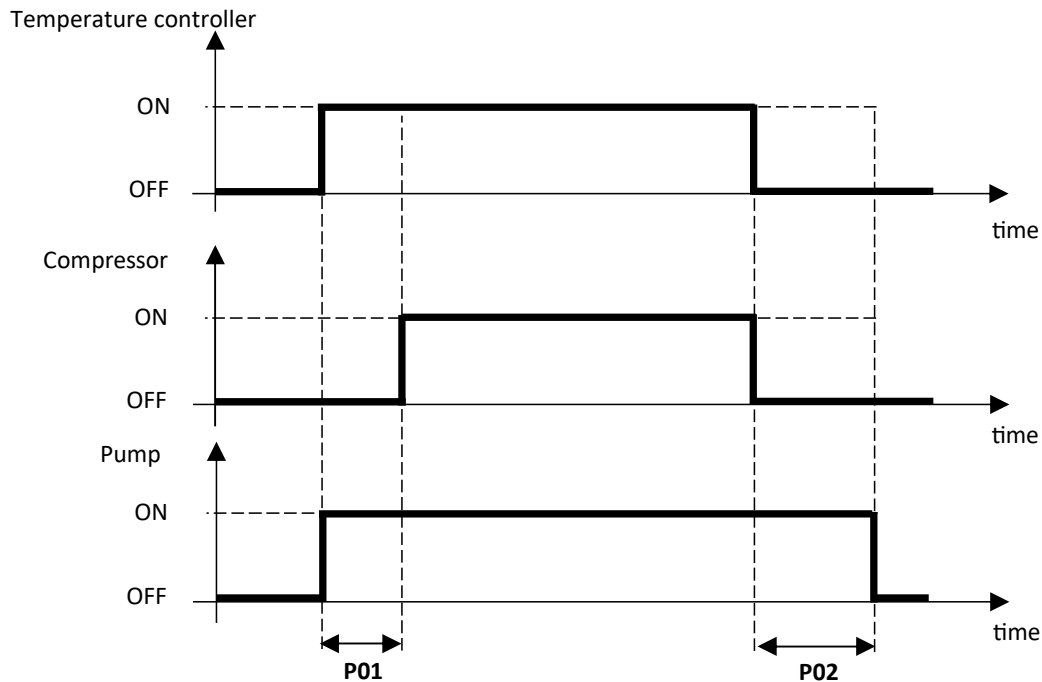

11.3 OPERATING ON CALL FROM TEMPERATURE CONTROLLER WITH PERIODIC ACTIVATION

The function is disabled if **P17=0** (default).

If **P03=1**, the circulator turns on periodically for a time defined by the parameter **P17** (in seconds) after a count, lasting a time set by parameter **P16** (in minutes), activated when the pump switches off because temperature control fulfilled.

With automatic reset flow switch alarm triggered, the pump is on even if the compressor is off.

The periodical function is a suspended if the antifreeze protection trips.

11.4 PROPORTIONAL REGULATION OF THE CIRCULATOR

The speed of the circulator changes depending on the temperature difference between the inlet water and outlet water of the heat exchanger, according to the diagram below, where:

- **P07**: Maximum speed = 95%
- **P08**: Minimum speed = 75%
- **P09**: modulating pump inlet/outlet water Delta T setting (°C) (according to model)
- **P10**: Modulating pump Delta = 3°C (default)

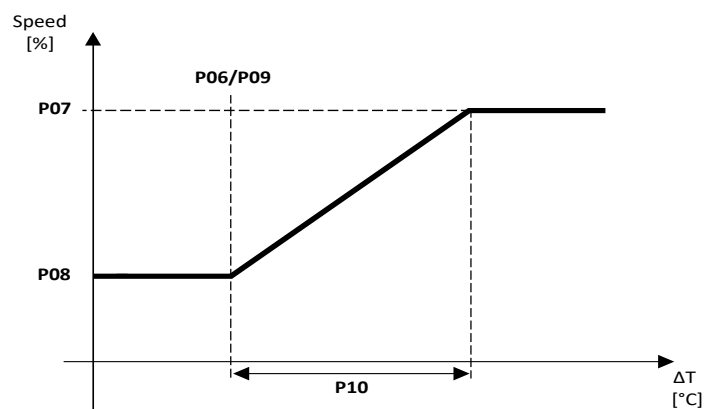

The circulator is at maximum speed in DHW production.

Note: If the parameter $r33 > 0$, then the circulator can be running on call even to activate the system and/or sanitary heater, see par.10.8.

11.5 SYSTEM VENTING

Function used to vent the system, with the circulator at maximum speed.

To enable the function:

- Controller **OFF**
- Access the parameters PRG ->PSS ->PRG -> (enter Service password)

- Press the **UP and DOWN** keys simultaneously for **3 seconds**

The circulator switches on at maximum speed, and then switches off after **5 minutes**.

The system venting cycle can be exited manually by pressing the **MODE/ESC** key, or by pressing the **UP and DOWN** keys simultaneously for 3 seconds.

During this function, the flow switch alarm is disabled, the maintenance technician must guarantee that there is water inside the system.

12. COMPRESSOR ON/OFF LOGIC

The restart of compressors is in operation of a set point referred to the inlet water temperature. It is based on calculation of ΔT_{set} which is the difference between outlet water temperatures and inlet water temperatures, detected while the compressor for thermoregulation is turning off.

By thermoregulation we mean the temperature control performed by the generator in order to guarantee the temperature strictly necessary to the system, reducing electricity consumption and achieving better indoor comfort.

The heat pump is supplied with a modulating control system based on the fluid outlet temperature, variable-speed compressors are able to adapt to the load variation, and reduce the fluctuations that would occur with an on/off system.

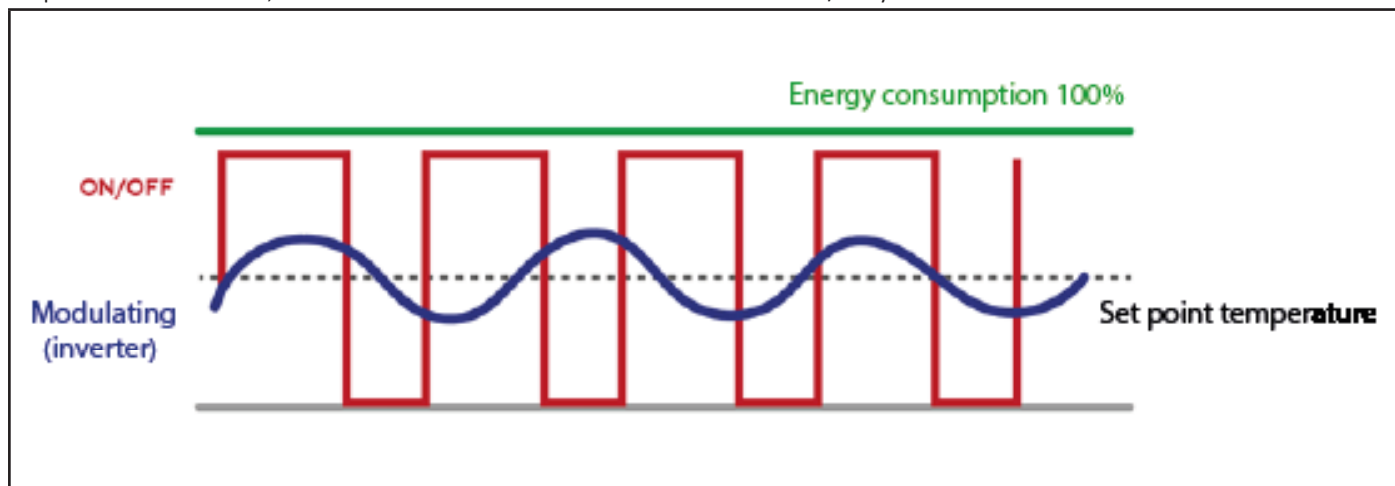

Modulating control systems can be:

- proportional
- proportional integrals

is the least complex control mode because it adjusts the capacity based on the difference between the actual control temperature and the target temperature (set point).

The temperature range within which the variation is activated to achieve the comfort temperature is defined as the 'proportional band' and represents the working range of the heat pump.

Parameters b01 and b02 are defined:

Parameter	Description
b01	band in chiller/cooling mode
b02	heat pump/heating band

13. REGULATION IN COOLING MODE

- $T_{w,out,set}$ = adjusted setpoint in cooling;
- $T_{w,in,set}$ = value of the water inlet probe recorded at the instant the compressor switches off when setpoint is reached;
- $\Delta T_{set} = T_{w,out,set} - T_{w,in,set}$;
- **b24** = cut-on hysteresis limitation;
- **b25** = delta cut-on compressor set= 2°C.

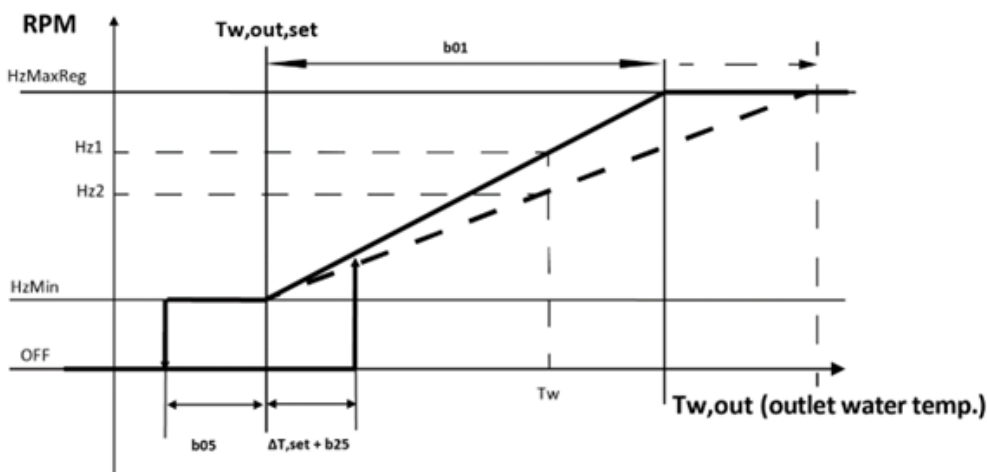

- The **compressor shutdown**: the compressor shutdown when $T_{w,out} < T_{w,out,set}$
- The **compressor restart** starts when $T_{w,out} > (T_{w,out,set} + \Delta T_{,set} + b25)$

EXCEPTION: The value of $\Delta T_{,set}$ is limited by b24.

If $\Delta T_{,set} > b24$ (default value 8°), the compressors restart when: $T_{w,out} > (T_{w,out,set} + b24 + b25)$.

13.1 REGULATION IN HEAT MODE

- $T_{w,out,set}$ = setting setpoint in heat mode
- $T_{w,in,set}$ = value of the water inlet probe recorded at the instant the compressor switches off when setpoint is reached.
- $\Delta T_{,set} = T_{w,out,set} - T_{w,in,set}$
- **b24** = cut-on hysteresis limitation;
- **b25** = compressor regulation delta cut-on = 2°C

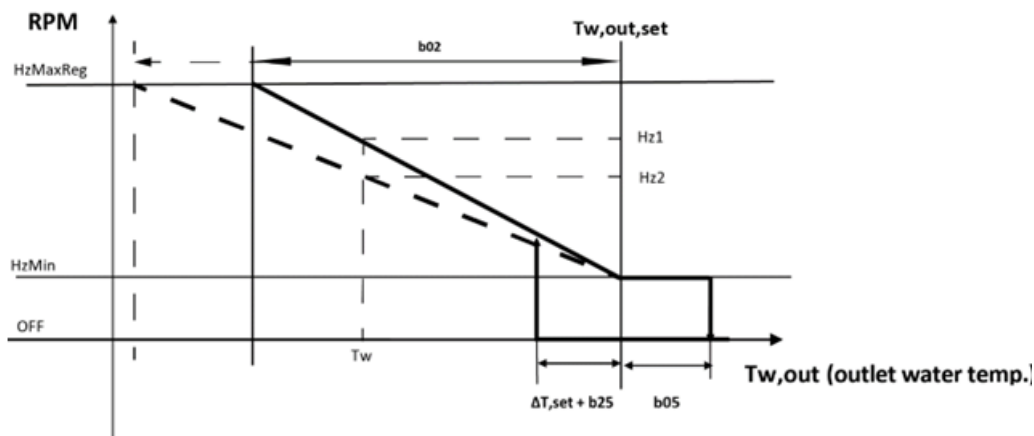

- The compressor shutdown: the compressor shutdown when is regulated by parameter b05 $T_{w,out} > T_{w,out,set}$
- The compressor restart when: $T_{w,out} < (T_{w,out,set} - \Delta T_{set} - b25)$

EXCEPTION: The value of $\Delta T_{,set}$ is limited by b24.

If $\Delta T_{,set} > b24$ (default value 8°), the compressors restart when: $T_{w,out} < (T_{w,out,set} - b24 - b25)$.

As can be deduced from the graphs above, the higher the band (higher b01 or b02 values, dotted lines in the graph), the lower the frequency at the same water outlet temperature ($H_{z1} > H_{z2}$).

The variables for deciding the correct proportional band value are:

- water content dedicated to the unit only
- type of terminals.

It is recommended to vary these values during start-up by considering a minimum value of 1 and a maximum of 4 °C.

Proportional Integral Method - PI:

With a value of $b07 \neq 0$ (Integral Time), this type of adjustment is much more accurate than the proportional one because it enables further reduce oscillations through continuous evaluation of the deviation.

The PI control provides a value from 0 to 100 % corresponding to the minimum and maximum possible frequency thanks to a constant scan that photographs the deviation between the actual measured temperature and the target temperature.

The error in cooling and heating mode will be calculated in this way, respectively:

- $\epsilon_f = T_{mis} - \text{Set point}$ (Error in cold or chiller mode)

- ϵc = Set point- Tmis (Error in heat or heat pump mode)

If the measured error is positive then there will be a variation otherwise, if negative, the frequency will not vary.

The two components (PI) work in synergy:

- ϵ unchanged: no change in power
- ϵ increasing: power increases due to the proportional component
- ϵ decreasing: power decreases due to the effect of the proportional component

The contribution of this component is directly proportional to the calculated error and inversely proportional to the value of the control band. For the same calculated error, the higher the set band, the lower the percentage of action, while for the same band, the higher the calculated error, the higher the percentage of action.

The calculated error, the higher the percentage of action.

For a better understanding of what is described, see the graphs below.

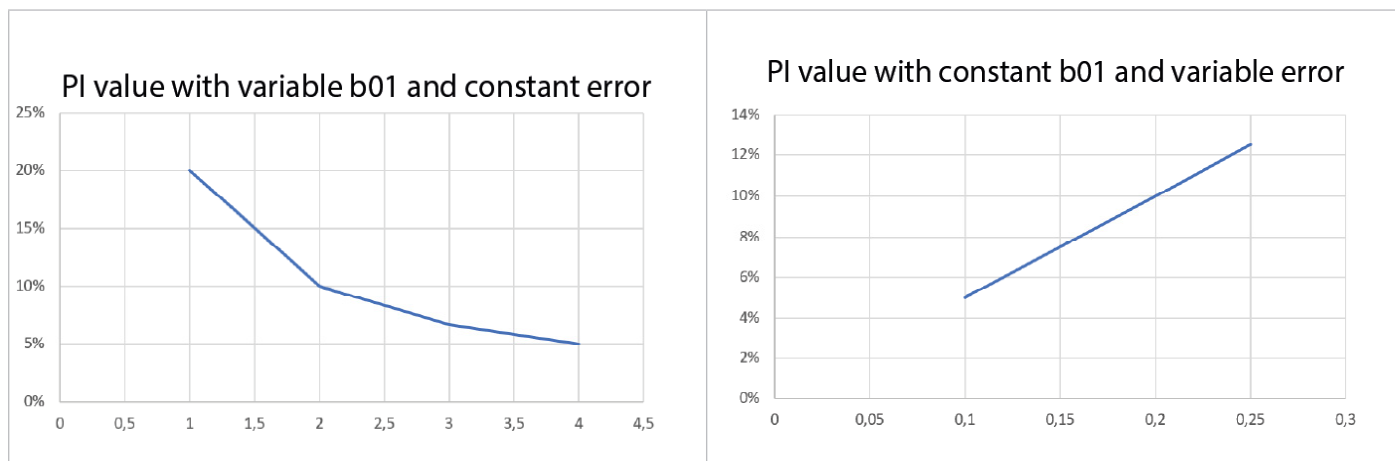

The contribution of this component is added to the power demand at each scan as a function of the integral time inversely proportional to the integral time b07:

Set-point set	35	35	35	35
b02	2	2	2	2
Tmis	34	34,5	34	34,5
ϵc	1	0,5	1	0,5
b07	50	50	100	100
integral contribution	10	5	5	2,5

N.B. if the power required is 100% or 0% there is no additional contribution or decrease.

The use of this regulation can be advantageous if the load variation is progressive without sudden variations because it would deliver more accurately the actual output of the heat pump in relation to the actual demand, whereas a only proportional component (b07=0) would be recommended for systems where the power demand variation is for a short period of time.

During commissioning, it must be considered whether it is more effective to work with a P or PI control in operation:

- water content dedicated to the unit only
- type of terminals
- of the load variation during start-up

The choice of regulation is fundamental to optimise the efficiency of the system and to reduce the number of starts/hour in order to achieve the correct thermodynamic balance and the correct lubrication of the mechanical parts in the compressor, it is recommended to choose them in order to have a continuous operation of the heat pump of at least 10 minutes.

The heat pump control regulates the maximum number of starts per hour via parameter C02 (which cannot be changed and is fixed by the manufacturer) in order to preserve the integrity of the compressor over time, but if necessary during the commissioning phase you can choose to delay the next start-up using parameter C01:

14. FAN CONTROL OF THE FINNED EXCHANGER

Ventilation control is a function of condensing pressure in chiller mode, and a function of evaporating pressure in heat pump mode.

The regulation of ventilation is dependent on the operating conditions of the machine.

A pre-ventilation occurs every time the compressor switches on and off.

15. CONTROLLER FUNCTIONS

The following is a list of the functions which can be activated in the machine controller; not all of them can be selected simultaneously. Values other than the default values can jeopardise proper operation of the unit. If in doubt on which value to set, contact our headquarters.

15.1 ANTIFREEZE PROTECTION HEATERS (IF KA ACCESSORY IS AVAILABLE)

If the optional KA kit is present, the function is active by default.

The water antifreeze heaters on the faces of the evaporator plates even activate with the machine off (but powered) when the delivery water temperature drops below **r02** °C (default 4°C) in "heating" mode or below **r03** °C (default 4°C) in "cooling" mode or when switched "OFF". The heaters are switched off when the temperature measured by the outlet water probe exceeds **r02+r06** in "heating" or **r03+r06** in "cooling" or when "OFF" (default value r06=2.0 °C).

The heating cable at the base of the machine activates when the outdoor air temperature drops below 3°C. It deactivates when the outdoor temperature rises above 5°C.

15.2 ENABLING DOMESTIC HOT WATER PRODUCTION

To activate the domestic hot water functions, connect a probe to be placed inside the tank to terminals **X17.1-X17.2** (enabled as analogue input). The sanitary function must be enabled after positioning and connecting the temperature probe.

I/O resource - Parameter	VALUE	Function
H10	0 (default)	Function disabled
	1	Function active in heating and cooling mode. The remote on-off function does not disable DHW production.
	2	Function active in heating and cooling mode. The remote on-off function disables DHW production.
	3	Function active in heating mode. The remote on-off function does not disable DHW production.
	4	Function active in heating mode. The remote on-off function disables DHW production.
	5	Function active in cooling mode. The remote on-off function does not disable DHW production.
	6	Function active in cooling mode. The remote on-off function disables DHW production.
ST6 can be activated via H17	6	DHW temperature probe enabling
DO6 can be activated via H84	6	DHW valve control

If the domestic hot water temperature is lower than its setting (set by default at 48°C, edited by accessing the menu **PRG->Set->SAN**) the machine activates the DHW valve and the compressor is set at maximum frequency, starting modulation one degree before the setting and switching off one degree after. When the set point is reached, the valve goes back to the rest condition and the compressor starts to regulate normally. Switching from utility water to domestic hot water, the working probe changes from "water outlet probe" to "DHW tank probe". Switching from winter mode to sanitary mode, the compressor does not switch off and is brought to the maximum frequency established by the controller, whereas switching from summer mode to domestic hot water, the compressor is switched off and waits a safety time. Defrosting is always carried out in winter mode on the utility side, and never on the domestic hot water tank.

NOTE:

-If **H10** = 1/3/5. Switching off the unit by remote control (remote on-off, see paragraph 10.4.1) does not affect domestic hot water operation. The unit goes to priority sanitary mode just powered on. The display on the machine shows the temperature detected by the probe inside the DHW tank. When the sanitary cycle has finished, the display goes back to showing the water outlet probe temperature.

If the remote ON-OFF digital input (terminals 15.1 / 15.2) is open, with sanitary function enabled (H10=1 and H20=6), the wording "SAN" will appear on the machine display. When the sanitary cycle has finished, the display goes back to showing "E00" indicating that the remote ON-OFF contact is open.

-If **H10** = 2/4/6, the remote on-off function disables domestic hot water production and operation of the heat pump in heating and cooling mode, system side.

15.2.1 MEMORISING THE PROBE IN HEATING MODE

Switching from utility water to domestic hot water, the working probe changes from "water outlet probe" to "DHW tank probe". For this reason, in heating mode, before entering sanitary mode, the last value read by the heat pump delivery probe is stored.

When sanitary temperature control is fulfilled, the system side temperature of reference goes back to that previously stored. The memory function interrupts:

- when the temperature read by the probe becomes lower than the stored value;
- or when a time equal to **b06** seconds (default b06 = 45) has elapsed.

15.2.2 HEATING MODE ON DHW STORAGE TANK

If the parameter **H130=1**, the machine exploits the DHW storage tank even for central heating. In these conditions, the outlet of the DHW valve is also enabled during operation in heating mode and not only in sanitary mode. The valve is deactivated during defrosting and in cooling mode. When **H130=1**, the DHW integration heater can be enabled also to act as system integration heater: to do this, set **r10=1** e **r15=2** (for other **r15** settings see Paragraph 10.6.3); furthermore no digital output must be set as system integration heater.

15.2.3 INSUFFICIENT HEAT EXCHANGE IN A DHW SYSTEM

During DHW production, if the heat pump flow probe detects a temperature higher than 78°C, the DHW valve output is de-energised (D06), and the value of the DHW probe at this time is recorded (Tsan,set).

-if the operation is San or Cool+San the compressor is stopped.

-If the operation is Heat+San, the system evaluates for b06 seconds whether there is a demand for heating from the system. If the system requires it, the compressor continues to work on the system, otherwise it is switched off.

- If the DHW resistor is present (e.g. DO3, H81=26), r15 = 0 or 1 and r24=2 or 3 it is activated until the DHW setpoint is met (and any offset).

The compressor restarts when the flow temperature of the heat pump falls below 75°C again and the temperature measured by the DHW probe

is lower than $T_{san,set} - 4^{\circ}\text{C}$.

15.3 REMOTE-CONTROLLED FUNCTIONS

Not all of the configurations can be activated and/or modified at the same time. The terminal block has digital inputs to control the unit via an external consent.

15.3.1 ON/OFF

The function is enabled by default on digital input ID 3 (terminals X15.1/X15.2). Remove the terminal block jumper to place the unit in standby (the text "E00" appears on the controller display). When the contact closes, the machine comes out of standby and the circulator switches on for 2 minutes. Function enabled by default (Parameter **H47=2**).

I/O Resource- Parameter	Function
ID3 can be activated via H47	Enables remote On /Off function

If the unit is switched off by remote control during defrosting, the heat pump finishes defrosting and then places itself in off mode via remote control.

15.3.2 SUMMER/WINTER MODE CHANGE

The function can be set on digital input ID 2 (terminals X16.1/X16.2). Heating or cooling mode of the heat pump can be managed by remote control.

I/O resource - Parameter	Value	Function
ID2 can be activated via H46	3	Open contact -> heat pump in cooling mode. Closed contact -> heat pump in heating mode.

The poles of the digital input can be swapped by setting $H75 = 2$.

15.3.3 ENABLING SG READY FUNCTION

The SG Ready function can be activated if the electricity grid to which the unit is connected is set up as Smart Grid Ready. To activate the SG Ready function, the grid supplier's SG Ready cables must be placed and connected to terminals ID2, C (SG Ready 1 digital input reference) and terminals A18, C (SG Ready 2 digital input reference). The following parameters must be configured to enable the function:

Resource I/O - Parameter	Default value	Function
ID2 active via H46	22	Closed contact -> SG Ready 1 call Contact open -> SG Ready 1 call not active
ID9 active via H53	23	Closed contact -> SG Ready 2 call Open contact -> SG Ready 2 call not active
b31	2°C	System Setpoint Offset for Smart Grid
b32	2°C	Sanitary Setpoint Offset for Smart Grid

The following table summarises the four operating states, relating to the status of the two digital inputs configured with the SG Ready function:

External signal	ID2 (SG1)	ID9 (SG2)	Description
1:0	Closed	Open	OFF command The heat pump remains forced to a shutdown condition, with the only exception of defrosting in progress; in this case, it waits until defrosting is complete before activating the function. The control board, in this phase, performs as if the thermoregulation status was satisfied.
0:0	Open	Open	Normal operation
0:1	Open	Closed	ON command In this state, the heat pump increases the set-point by an offset defined by parameters b31, b32. The logic differs in two cases, with or without configuration of the 'room call' device (with enabling of a related digital input, Room Thermostat). a. Configuration without 'room call' device When the external input 0:1 occurs and the compressor is on, the control logic instantaneously applies the offset; When the external input 0:1 occurs and the compressor is off the control logic does not instantaneously apply the offset but waits for the compressor to activate the offset. Configuration with 'room call' device: b. When external input 0:1 occurs and there is an active 'room call', the control logic instantaneously applies the offset; when external input 0:1 occurs and there is no active 'room call', the control logic does not instantaneously apply the offset but waits for the 'room call' to be activated and only then applies the offset.

External signal	ID2 (SG1)	ID9 (SG2)	Description
1:1	Closed	Closed	<p>Force ON command</p> <p>Compared to the previous case, the heat pump forces ON immediately by increasing the set-point of an offset defined by parameters b31, b32, with the distinction of the following two cases:</p> <p>a. Configuration without 'room call' device When the external 1:1 input occurs, the control logic instantly applies heat offsets and/or san offsets, whether the compressor is on or off;</p> <p>b. Configuration with 'room call' device When the external 1:1 input occurs, the control logic instantaneously applies heat offsets and/or sanitary offsets, whether there is an active room call or not; this means that the control logic immediately forces the set point to increase by a value equal to the offset, regardless of the room call status or regardless of the compressor status.</p>

The following control logic applies to both conditions 'Command ON-external input 0:1' and 'Command FORCE ON-external input 1:1':

- a. If both offsets are enabled (Heating offset + Sanitary offset), the control logic does not apply the offset on the sanitary set instantaneously but only when the heating operation mode is satisfied.
- b. If the pdc is operating in DHW mode, the DHW offset is not applied instantaneously but the DHW set-point is satisfied first. It then returns to heating mode by applying the heating set-point+offset and only then applies the offset on the DHW set-point (DHW set-point+offset).
- c. If the machine is thermoregulating using the "second set-point" function the offset on the system set-point is not applied.

15.4 SYSTEM WATER REMOTE PROBE

In some system solutions (e.g. heat pump in parallel to boiler on same hydronic circuit and shut off diverter valve) it could be necessary to enable a system remote temperature probe so that the controller can correctly process the management.



I/O resource- Parameter	Value	Description
ST7 can be activated via H18	41	Enables system remote probe

In the presence of the system remote probe, if the storage tank temperature is satisfied, it is avoided to activate the compressors even if the regulation probe requires it.

The conditions for the application of thermoregulation lockout are as follows:

- the heat pump is not performing DHW
- the heat pump is not defrosting
- all compressors are switched-off

The blocking conditions are as follows:

Operating mode		Conditions inhibiting the restart of thermoregulation
	heating	System remote probe > setpoint - b22
	cooling	System remote probe < setpoint + b22

Nota: b22=5°C. See paragraph 13.

15.5 FUNCTIONS DIGITAL OUTPUTS CAN BE ACTIVATED

If the machine block signal function is not active, one of the following signals can be configured at the DO7/N terminals and the user terminal block.

15.5.1 MACHINE BLOCK

Configured by default, a voltage output signalling the presence of an alarm.

Resource I/O (Parameter)	Value	Function
DO7 attivabile via H85	47	Alarm signalling

15.5.2 AUXILIARY RESISTANCES

In some system solutions, it may be necessary to use an integration resistor for the system and/ or for the DHW. To define the mode of intervention of the integration resistors, the parameter r24 must be set:

- r24=0 integration resistors not used;
- r24=1 use of system integration resistor only;
- r24=2 use of DHW integration resistor only;
- r24=3 use of both system integration resistor and domestic hot water integration resistor.

15.5.2.1 SYSTEM HEATER

If the regulation temperature remains below **water setpoint in heating (Hea) – 0.5°C** for a time equal to **r12** the integration heater is activated according to operation of the machine in joint time slots or in substitution, as indicated in Paragraph 10.11.

The heater switches off when the setpoint is reached (also taking into account an offset set with parameters **r29** or **r30**).

If the regulation temperature remains below the **water setpoint minus r11** (°C) and the machine is blocked due to triggering of an alarm, the heater switches on. It switches off when the machine exits the alarm block.

I/O resource - Parameter	Value	Function
r10	1	Function enabling
r11	0.5°C (default)	Heaters in heating integration delta
r12	8 minutes (default)	Heaters in heating integration delta
r24	1/3	Type of use of heaters
D03 can be activated via H81	22	System integration heater

15.5.2.2 PLANT HEATER IN DEFROST

During the **defrost cycle** (see Paragraph 10.12.2), setting **r21=1** (in addition to **r10=1** and **r24=1** or **3**) activates the plant side electric heater, if requested (regulation temperature lower than **water setpoint -r11**(°C), without waiting the time defined by **r12**).

15.5.2.3 DHW HEATER

Function which can be activated instead of managing the plant heater

This is an additional resource for heating the domestic hot water storage tank if the compressor alone is not capable of fulfilling the request in a reasonable time.

If domestic hot water production lasts longer than **r16** (minutes) or if the machine blocks due to triggering of an alarm, the heater switches on. It switches off when the unit finishes domestic hot water production (also taking into account an offset on the setpoint with parameter **r31**, as explained in Paragraph 10.11.1).

I/O resource - Parameter	Value	Function
r15	1	Function enabling
r16	8 minutes (default)	DHW integration activation delay
r24	2/3	Type of use of heaters
D03 can be activated via H81	26	System integration heater

Note: The domestic hot water function must be enabled (see paragraph 10.2)

15.5.2.4 SINGLE SYSTEM/DHW INTEGRATION HEATER

By configuring the DHW integration heater, it is possible to use this heater declared also as plant integration heater, setting the parameter **r15=2** and **r24=3**.

In case of plant integration demand, the heater declared as DHW integration is activated, thus allowing to have a single integration heater for plant, domestic hot water and plant under defrost.

15.5.2.5 INTEGRATION HEATER SELECTION MODE

The priority can be set in the order to activate the plant side and sanitary side integration heaters; specifically the configurations are:

1. **r14=0** (default), the heaters can be activated simultaneously, if present;
2. **r14=1**, the heaters can be activated, excluding one another:
 - 2.1. **r20=0**, priority to the plant (the DHW heater only switches on if the temperature control for the plant side heater is fulfilled);
 - 2.2. **r20=1**, priority to DHW (the plant side heater only switches on if the temperature control for the sanitary side heater is fulfilled).

15.5.2.6 CIRCULATOR MANAGEMENT WITH HEATER ON

The circulator of the heat pump can be activated when the plant and/or DHW integration heaters are active with the compressors not running (by substitution, by alarm or by integration in bracket II or III).

-**r33** = 0: The circulator of the heat pump is activated on demand of the compressors or boiler,

-**r33** = 1: The circulator of the heat pump is activated if the plant heater is active.

-**r33** = 2: The circulator of the heat pump is activated if the DHW heater is active.

-**r33** = 3: The circulator of the heat pump is activated if the plant or DHW heater is active.

The circulator switches off after post-pumping (**P02**).

15.5.3 BOILER ENABLING

Function which can be activated instead of managing the double setpoint.

This is an additional resource to enable the boiler in integration or substitution of the heat pump.

Define the use mode by setting the parameter **r23**:

- **r23=0** (default) boiler not used (operating priority of heaters);
- **r23=1** only boiler on plant used (operating priority of heaters);
- **r23=2** only DHW boiler used (operating priority of heaters);
- **r23=3** DHW and plant boiler used (operating priority of heaters);
- **r23=4** only boiler on plant with priority used (no heater operating priority);
- **r23=5** only boiler in sanitary with priority used (no heater operating priority);
- **r23=6** boiler on plant and in sanitary with priority used (no heater operating priority);

Define the supply of the boiler, setting parameter **r32**:

- **r32 = 0**: boiler without circulator with temperature control by heat pump,
- **r32 = 1**: boiler with autonomous circulator with temperature control by heat pump;
- **r32 = 2**: boiler without circulator with autonomous temperature control;
- **r32 = 3**: boiler with circulator with autonomous temperature control.

I/O resource- Parameter	Value	Function
r10	1	Plant integration enabling
r12	8 minutes (default)	Plant integration activation delay
r15	1	DHW integration enabling
r16	8 minutes (default)	DHW integration activation delay
r23	1÷6	Type of use of boiler
r32	1÷3	Boiler supply
DO3 can be activated via H81	29	Boiler enabling

15.5.4 ACTIVATION OF INTEGRATION HEATERS AND BOILER IN JOINT OPERATION AND IN SUBSTITUTION OF HEAT PUMP COMPRESSOR

The auxiliary parts that can be used for joint operation or for operation in substitution are:

- **boiler**
- **plant integration heater**
- **DHW integration heater**

Considering the operating modes in heating and/or DHW, there are 4 operating areas:

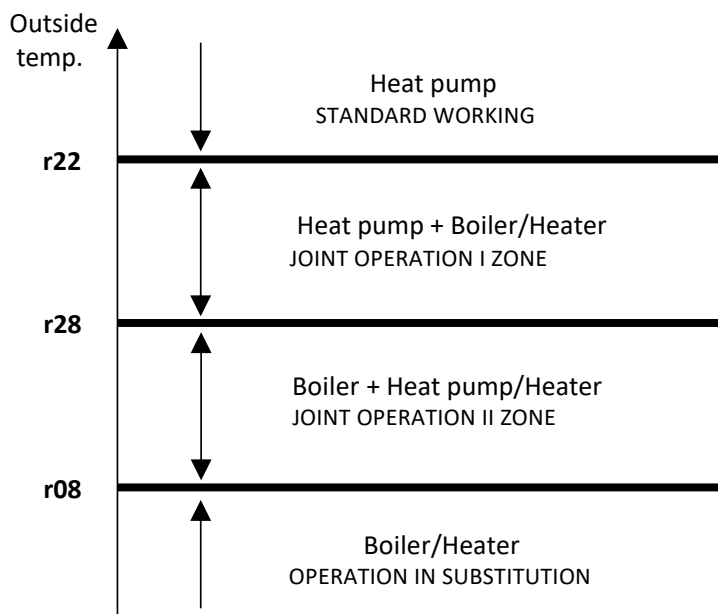

If you need to change the values of the parameters **r22**, **r28**, **r08**, follow $r22 \geq r28 \geq r08$.

Setting **r22=r28** allows you to eliminate the zone relative to joint operation bracket I; setting **r28=r08** allows you to eliminate the zone relative to joint operation bracket II; setting **r22=r28=r08** allows you to eliminate both brackets relative to joint operation.

Do not modify value **r08**, as it could jeopardise operation of the unit

15.5.4.1 OPERATION IN HEAT PUMP MODE

Normal operation of the heat pump in which the integration resistors and/or the boiler only intervene when a heat pump alarm is triggered.

15.5.4.2 JOINT OPERATION (I BRACKET)

If the outdoor temperature is between **r22** and **r28**, the compressor operates in synergy with the auxiliary heaters in winter or DHW mode. In this operating bracket, first the heat pump is activated and after **r12** minutes the plant side auxiliary heaters, or after **r16** minutes the sanitary side auxiliary heaters.

The intervention priorities are defined by the parameters **r14**, **r20**, **r23**, **r24**.

It goes back to **normal** operation if the outdoor temperature is greater than $r22+1.0$ (°C).

NOTE: In the joint operating bracket, the boiler is temperature controlled by the plant water remote probe (if enabled). In particular, if the temperature detected by the remote probe is lower than the **Hea** setpoint, the boiler is switched on and then will go off when the temperature detected by the remote probe is higher than the **Hea** setpoint. The heat pump follows the activation logic described in paragraph 10.5.

If the remote plant water probe is not enabled, the boiler will be managed by the delivery probe of the heat pump.

15.5.4.3 JOINT OPERATION (II BRACKET)

If the outdoor temperature is between **r28** and **r08**, the compressor operates in synergy with the auxiliary heaters.

In this operating bracket, first the boiler is activated, then the heat pump and auxiliary heaters intervene after a time defined by **r12** (minutes)

for the plant side and **r16** (minutes) for the sanitary side.

The intervention priorities are defined by the parameters **r14**, **r20**, **r23**, **r24**.

It goes back to normal operation if the temperature rises above **r28+1.0** (°C).

Note: In the joint operating bracket, the boiler is temperature controlled by the plant water remote probe (if enabled). In particular, if the temperature detected by the remote probe is lower than the **Hea** setpoint, the boiler is switched on and then will go off when the temperature detected by the remote probe is higher than the **Hea** setpoint. The heat pump follows the activation logic described in paragraph 10.5.

If the remote plant water probe is not enabled, the boiler will be managed by the delivery probe of the heat pump.

15.5.4.4 OPERATION IN SUBSTITUTION

If the outdoor temperature drops below **r08** use of the heat pump compressor will be inhibited.

- If the auxiliary system is composed of plant and/or DHW heaters, they are active in substitution of the compressor with defined times, **r12** (minutes) for plant side and **r16** (minutes) for sanitary side.

Whereas in the operation in substitution bracket, the integrations do not need to be enabled with **r10** or **r15** as the heaters need to operate in substitution (and not in integration) of the heat pump (therefore simply select the type of use with the parameter **r24**).

- If the auxiliary system is a boiler with autonomous circulator (**r32 = 1 or 3**).

The circulator of the heat pump is off, after **P01** (default 30 seconds) the boiler is enabled.

NOTE: With water side antifreeze protection, the pump used is activated (or remains active) anyhow.

- If the auxiliary system in substitution is a boiler with autonomous temperature control (**r32 = 0 or 2**).

The boiler is enabled regardless of the temperature control of the heat pump.

- If the auxiliary system in substitution is a boiler without circulator (**r32 = 0 or 2**).

The circulator of the heat pump is on when the boiler is enabled.

The compressor switches back on if the temperature rises above **r08+ r09** (°C) (**r09=1.0** °C by default).

15.5.4.5 OPERATING BRACKETS - ACTIVATION OF INTEGRATION HEATERS (plant remote water probe not enabled)

The possible configurations of the integration parameters are listed in tables 1,2,3 and 4 shown below, divided by operating brackets (the operating modes and possible values of the parameters are indicated in the "STATUS" boxes and in the parameters "rxx" so that a given order of intervention of the integrations occurs in a certain operating mode of the unit; other statuses and values of the parameters can be selected instead and therefore they are provided in the same cell separated by the symbol "/").

TABLE 1. NORMAL OPERATION IN HEAT PUMP									
N°	INTEGRATIONS INTERVENTION ORDER (with set-point not reached and machine blocked by alarm)	STATUS	OPERATION	r10	r15	r12	r16	r23	r24
1	1) Plant integration heater	HEAT/ HEAT+SAN	HEAT	1	0/1/2	/	/	0/2/5	1/3
2	1) Boiler	HEAT/ HEAT+SAN	HEAT	0/1/2	0/1/2	/	/	1/3/4/6	0/2
3	1) Plant integration heater 2) After 12 mnutes, boiler	HEAT / HEAT+SAN	HEAT	1	0/1/2	Set the min- utes	/	1/3	1/3
4	1) Boiler 2) After r12 minutes, plant integra- tion heater	HEAT / HEAT+SAN	HEAT	1	0/1/2	Set the min- utes	/	4/6	1/3
5	1) DHW integration heater	HEAT+SAN	DHW	0/1	1	/	/	0/1/4	2/3
6	1) Boiler	HEAT+SAN / COOL+SAN	DHW	0/1	0/1/2	/	/	2/3/5/6	0/1
7	1) DHW integration heater 2) After r16 minutes, boiler	HEAT+SAN	DHW	0/1	1	/	Set the min- utes	2/3	2/3
8	1) Boiler 2) After r16 minutes, DHW integra- tion heater	HEAT+SAN	DHW	0/1	1	/	Set the min- utes	5/6	2/3
9	1) Plant/DHW integration heater	HEAT / HEAT+SAN	HEAT/DHW	1	1	/	/	0	3
10	1) Boiler	HEAT / HEAT+SAN	HEAT/DHW	0/1	0/1/2	/	/	3/6	0
11	1) Plant/DHW integration heater 2) After r12 minutes, boiler	HEAT / HEAT+SAN	HEAT/DHW	1	1	Set the min- utes	Set the min- utes	3	3
12	1) Boiler 2) After r12 minutes, plant/DHW in- tegration heater	HEAT / HEAT+SAN	HEAT/DHW	1	1	Set the min- utes	Set the min- utes	6	3

TABLE 2. JOINT OPERATION, BRACKET 1									
N°	INTERVENTION ORDER (with setpoint not reached)	STATUS	OPERATION	r10	r15	r12	r16	r23	r24
1	1) Heat pump 2) After r12 minutes, plant integration heater	HEAT / HEAT+SAN	HEAT	1	0/1/2	Set the min- utes	/	0/2/5	1/3

TABLE 2. JOINT OPERATION, BRACKET 1

N°	INTERVENTION ORDER (with setpoint not reached)	STATUS	OPERATION	r10	r15	r12	r16	r23	r24
2	1) Heat pump 2) After r12 minutes, boiler	HEAT / HEAT+SAN	HEAT	0/1	0/1/2	Set the min- utes	/	1/3/4/6	0/2
3	1) Heat pump 2) After r12 minutes, plant integration heater 3) After further r12 minutes, boiler	HEAT / HEAT+SAN	HEAT	1	0/1/2	Set the min- utes	/	1/3	1/3
4	1) Heat pump 2) After r12 minutes, boiler 3) After further r12 minutes, plant integration heater	HEAT / HEAT+SAN	HEAT	1	0/1/2	Set the min- utes	/	4/6	1/3
5	1) Heat pump 2) After r16 minutes, plant integration heater	HEAT+SAN	DHW	0/1	1	/	Set the minutes	0/1/4	2/3
6	1) Heat pump 2) After r16 minutes, boiler	HEAT+SAN/ HEAT	DHW	0/1	0/1/2	/	Set the minutes	2/3/5/6	2/3
7	1) Heat pump 2) After r16 minutes, plant integration heater 3) After further r16 minutes, boiler	HEAT+SAN	DHW	0/1	1	/	Set the minutes	2/3	2/3
8	1) Heat pump 2) After r16 minutes, boiler 3) After further r16 minutes, DHW integration heater	HEAT+SAN	DHW	0/1	1	/	Set the minutes	5/6	2/3
9	1) Heat pump 2) After r12 minutes, plant/DHW integration heater	HEAT / HEAT+SAN	HEAT/DHW	1	1	Set the min- utes	Set the minutes	0	3
10	1) Heat pump 2) After r12 minutes, boiler	HEAT / HEAT+SAN	HEAT/DHW	0/1	0/1/2	Set the min- utes	Set the minutes	3/6	0
11	1) Heat pump 2) After r12 minutes, plant/DHW integration heater 3) After further r12 minutes, boiler	HEAT / HEAT+SAN	HEAT/DHW	1	1	Set the min- utes	Set the minutes	3	3
12	1) Heat pump 2) After r12 minutes, boiler 3) After further r12 minutes, plant/DHW integration heater	HEAT / HEAT+SAN	HEAT/DHW	1	1	Set the min- utes	Set the minutes	6	3

TABLE 3. JOINT OPERATION, BRACKET 2

N°	INTERVENTION ORDER (with setpoint not reached)	STATUS	OPERATION	r10	r15	r12	r16	r23	r24
1	1) Boiler 2) After r12 minutes, heat pump	HEAT / HEAT+SAN	HEAT	0/1	0/1/2	Set the min- utes	/	1/3/4/6	0/2
2	1) Boiler 2) After r12 minutes, plant integration heater 3) After further r12 minutes, heat pump	HEAT / HEAT+SAN	HEAT	1	0/1/2	Set the min- utes	/	1/3	1/3
3	1) Boiler 2) After r12 minutes, heat pump 3) After further r12 minutes, plant integration heater	HEAT / HEAT+SAN	HEAT	1	0/1/2	Set the min- utes	/	4/6	1/3
4	1) Plant integration heater 2) After r12 minutes, heat pump	HEAT / HEAT+SAN	HEAT	1	0/1/2	Set the min- utes	/	0/2/5	1/3
5	1) Boiler 2) After r16 minutes, heat pump	HEAT+SAN	DHW	0/1	0/1/2	/	Set the min- utes	2/3/5/6	0/1
6	1) Boiler 2) After r16 minutes, DHW integration heater 3) After further r16 minutes, heat pump	HEAT+SAN	DHW	0/1	1	/	Set the min- utes	2/3	2/3
7	1) Boiler 2) After r16 minutes, heat pump 3) After further r16 minutes, DHW integration heater	HEAT+SAN	DHW	0/1	1	/	Set the min- utes	5/6	2/3
8	1) DHW integration heater 2) After r16 minutes, heat pump	HEAT+SAN	DHW	0/1	1	/	Set the min- utes	0/1/4	2/3
9	1) Boiler 2) After r12 minutes, heat pump	HEAT / HEAT+SAN	HEAT/DHW	1	1	Set the min- utes	Set the min- utes	3/6	0

TABLE 3. JOINT OPERATION, BRACKET 2

N°	INTERVENTION ORDER (with setpoint not reached)	STATUS	OPERATION	r10	r15	r12	r16	r23	r24
10	1) Boiler 2) After r12 minutes, plant/DHW integration heater 3) After further r12 minutes, heat pump	HEAT / HEAT+SAN	HEAT/DHW	1	1	Set the minutes	Set the minutes	3	3
11	1) Boiler 2) After r12 minutes, heat pump 3) After further r12 minutes, plant/DHW integration heater	HEAT / HEAT+SAN	HEAT / SANITARIO	1	1	Set the minutes	Set the minutes	6	3
12	1) Plant/DHW integration heater 2) After r12 minutes, heat pump	HEAT / HEAT+SAN	HEAT/DHW	1	1	Set the minutes	Set the minutes	0	3

TABLE 4. OPERATION IN SUBSTITUTION

N°	INTERVENTION ORDER (with setpoint not reached)	STATUS	OPERATION	r10	r15	r12	r16	r23	r24
1	1) Boiler 2) After r12 minutes, Plant integration heater	HEAT / HEAT+SAN	HEAT	0/1	0/1/2	Set the minutes	/	4/6	1/3
2	1) Plant integration heater 2) After r12 minutes, boiler	HEAT / HEAT+SAN	HEAT	0/1	0/1/2	Set the minutes	/	1/3	1/3
3	1) Boiler 2) After r12 minutes, DHW integration heater	HEAT+SAN	DHW	0/1	0/1/2	/	Set the minutes	5/6	2/3
4	1) DHW integration heater 2) After r12 minutes, boiler	HEAT+SAN	DHW	0/1	0/1/2	/	Set the minutes	2/3	2/3
5	1) Boiler 2) After r12 minutes, Plant/DHW integration heater	HEAT / HEAT+SAN	HEAT/DHW	0/1	0/1/2	Set the minutes	Set the minutes	6	3
6	1) Plant/DHW integration heater 2) After r12 minutes, boiler	HEAT / HEAT+SAN	HEAT/DHW	0/1	0/1/2	Set the minutes	Set the minutes	3	3
7	1) Boiler	HEAT / HEAT+SAN	HEAT	0/1	0/1/2	Set the minutes	/	1/3/4/6	0/2
8	1) Plant integration heater	HEAT / HEAT+SAN	HEAT	0/1	0/1/2	Set the minutes	/	0/2/5	1/3
9	1) Boiler	HEAT+SAN	DHW	0/1	0/1/2	/	Set the minutes	2/3/5/6	0/1
10	1) DHW integration heater	HEAT+SAN	DHW	0/1	0/1/2	/	Set the minutes	0/1/4	2/3
11	1) Boiler	HEAT / HEAT+SAN	HEAT/DHW	0/1	0/1/2	Set the minutes	Set the minutes	3/6	0
12	1) Plant/DHW integration heater	HEAT / HEAT+SAN	HEAT/DHW	0/1	0/1/2	Set the minutes	Set the minutes	0	3

Table 5 shows the settings to be configured to enable the integrations in “summer and sanitary” mode (in this case the only activation that can be activated is the DHW integration heater and the division into operating brackets does not apply).

TABLE 5. OPERATION IN COOL+SAN (DHW RUNNING)

N°	INTEGRATIONS INTERVENTION ORDER -With setpoint not reached after r16 minutes from the start-up of the compressor or with setpoint not reached with machine blocked by alarm.	STATUS	OPERATION	r10	r15	r12	r16	r23	r24
1	1) DHW integration heater	COOL+SAN	DHW	0/1	1	/	Set the minutes	0/1/2/3/4/5/6	2/3

Table 6 shows the behaviour of the plant and DHW integration heaters in all the operating modes of the unit.

TABLE 6. INTEGRATION HEATERS OPERATION

N°	STATUS	OPERATION	PLANT INTEGRATION HEATER	DHW INTEGRATION HEATER
1	HEAT+SAN	HEAT	Works as indicated in TABLE 1,2,3 and 4.	In “HEAT+SAN”, by default sanitary temperature control has priority over that of the plant, therefore if required by the temperature control, the unit goes to “SANITARY” mode and the DHW integration heater acts as indicated in TABLES 1,2,3 and 4.

TABLE 6. INTEGRATION HEATERS OPERATION

N°	STATUS	OPERATION	PLANT INTEGRATION HEATER	DHW INTEGRATION HEATER
2	HEAT+SAN	DHW	<p>Only if all 3 of the following conditions are met: -the output is configured for Plant integration heater; -r24=1/3; -plant water temperature remote probe present and configured; the plant integration heater is activated in the following situations: - r12 minutes after the start of its count activated in "HEAT" mode previously running (see line 1); - if its count is not already activated in the previous "HEAT" mode, r12 minutes after the temperature control demand. - In SANITARY mode, with remote probe not configured, the plant integration heater is deactivated or any of its counts are interrupted. - With "remote on-off" contact open, the Plant integration heater is deactivated.</p>	Works as indicated in TABLES 1,2,3 and 4.
3	COOL+SAN	DHW	Cannot be activated	Works as indicated in TABLE 5.
4	COOL+SAN	COOL	Cannot be activated	Cannot be activated

15.5.4.6 AUXILIARY SYSTEMS OFFSET MANAGEMENT

Lastly you may establish that the boiler and/or integration heaters (according to the resources and selected priorities) have a setpoint in heating mode and in sanitary mode higher than that of the heat pump. This is achieved by setting an offset on the following setpoints:

- **r29** = First setpoint temperature offset for boiler and plant heaters (**G02**);
- **r30** = Second setpoint temperature offset for boiler and plant heater (**G05**);
- **r31** = Temperature offset for boiler and DHW heaters (**G03**);

This way the heat pump stops at the setpoint (**G02,G03,G05**) and the temperature difference, according to the set offset, will be supplied by the boiler and/or heaters.

15.5.5 SYSTEM SEASON

A digital output can be configured indicating the operating season of the unit, plant side.

The output is active in summer mode, while it is deactivated in OFF or heating mode.

During DHW production and defrosting, the output maintains the setting of the source season.

I/O Resource (Parameter)	Value	Function
DO7 can be activated via H85	31	Plant season warning

15.5.6 ALARM

A voltage output can be configured to signal the presence of an alarm.

I/O Resource Parameter	Value	Function
DO7 can be activated via H85	24	Alarm warning

15.5.7 DEFROST

A digital output can be configured signalling defrosting in progress.

I/O Resource Parameter	Value	Function
DO7 can be activated via H85	21	Defrost in progress warning

15.6 DEFROST CYCLE

The defrost cycle is only active in heat pump mode and is used to prevent the formation of ice on the surface of the air/air coil. The formation of ice on the evaporator, which is quite frequent with very low outdoor temperatures, in addition to considerably downgrading the thermodynamic performance of the unit, also risks damaging the unit itself.

If the unit is switched off by remote control during defrosting, the heat pump finishes defrosting and then places itself in off mode via remote control.

15.7 COMPRESSOR CRANKCASE HEATER

The crankcase heater is activated if the compressor has been off for at least 30 minutes and if the discharge temperature is below a certain threshold of 20 °C (with hysteresis of 2.0°C). The crankcase heater is disabled when the compressor starts back up.

15.8 DOUBLE SET-POINT

This function introduces a second working set-point on the plant side, both in cooling and heating mode.

The user terminal board allows a consent to be connected to switch from the first to the second set-point and configured at digital input ID9 with parameter **H53 = 26**. The valve, on the other hand, is connected in the terminal board to digital output DO7 and is configured via parameter **H85**.

Parameter	VALUE	Function
H53	26	Second set-point call
H85	25	3-way valve for radiant panels
H129	0	Function disabled (default)
	1	Function configured but not active
	2	Enabled only in cooling mode
	3	Enabled only in heating mode
	4	Enabled in cooling and heating mode
H138	0	DHW second setpoint function disabled (default)
	1	Enabled the second DHW set point in cooling mode
	2	Enabled the second DHW set point in heating mode
	3	Enabled the second DHW set point in cooling and heating mode

15.9 MINIMUM HZ FUNCTIONALITY

Configuring parameter L02=1 and L03≠0 reduces the nominal operating Hz of the compressor.

Parameter	VALUE	Function
L02	0	Function not active
	1	Enabling minimum Hz
L03	0	Function not active
	1	Function active only in cooling mode
	2	Function active only in heating mode
	3	Function active only in sanitary mode
	4	Function active in cooling and sanitary mode
	5	Function active in heating and sanitary mode
	6	Function active in cooling and heating mode
	7	Function always active

With the function active, the output and power of the unit are limited, for additional information see the installer user manual. Configuring a digital input ID9 with parameter H53=21, the function can be managed.

Parameter	VALUE	Function
H53	0 (default)	Function disabled
	21	Open contact -> standard mode Closed contact -> mode Hz min/max

15.10 MAXIMUM HZ FUNCTIONALITY

Activating the function increases the power of the unit, please contact us for information.

15.11 FLOWMETER

There is a flowmeter in each unit; it has the following characteristics:

Unit	Water measuring range [L/min]	Flow speed [m/s]	Power supply [Vdc]	Current consumption without load	DN
0106 0109	3.5 - 50	0,290 - 4,145	4,75 - 33	<5mA	15

Unit	Water measuring range [L/min]	Flow speed [m/s]	Power supply [Vdc]	Current consumption without load	DN
0112 0115 0118	5,0 - 85	0,265 - 4,509	4.75 - 33	<5mA	20

you can read the flow value in L/min from the remote display by pressing Enter -> SYS, and scrolling to S014.

16. FUNCTIONS THAT CAN BE ACTIVATED WITH HI-T2 ACCESSORY (OPTIONAL)

This is a touch screen remote control for centralised management of a chiller/heat pump network. It includes humidity and temperature sensors for the thermo hygrometric analysis of the environment and for the management of the double set point for radiant floor heating systems that use a dehumidification system.

The intuitive interface simplifies the use of the controller; all the functions can be easily set through the use of an easy to understand synoptic. The Hi-T remote control allows you to manage the following functions:

- Remote management;
- Management of a network, up to 7 heat pumps;
- Zone thermostat;
- Screed function;
- Antilegionella disinfection;
- Double set-point and humidity measurement;
- Dew point control;
- Climatic compensation;
- Booster circulator management;
- Management of single pump in a network;
- Alarm diagnostic system.

For further information, see the user-installer manual, or contact our headquarters.

17. FUNCTIONS THAT CAN BE ACTIVATED WITH GI3 MODULE (OPTIONAL)

The Gi module is an optional kit which allows you to manage the following functions:

- Booster circulator management with the aid of a room thermostat (not supplied);
- Management of a plant side mixer valve both in heating and cooling mode;
- Solar – thermal integration management.

17.1 I/O RESOURCES OF THE CONTROLLER

The following is the list of I/O (inputs and outputs) that can be set to activate the functions of the controller.

Resource	Parameter	Terminal block XGI	Factory configuration		Description
			Default value	Function	
ST 5E	H27	1.1 / 1.2	0	Not set	Analogue input configurable with an NTC-10KΩ probe at 25°C β 3435
ST 6E	H28	2.1 / 2.2	0	Not set	Analogue input configurable with an NTC-10KΩ probe at 25°C β 3435
ST 7E	H29	3.1 / 3.2	0	Not set	Analogue input configurable with an NTC-10KΩ probe at 25°C β 3435
ID 9E	H63	4.1 / 4.2	0	Not set	Voltage-free digital input
DO 1E	H86	1.1 (phase) 2.2 (neutral)	0	Not set	230Vac, 50Hz, 2A (AC1) single-phase live output.
DO 2E	H87	2.1 (phase) 2.2 (neutral)	0	Not set	230Vac, 50Hz, 2A (AC1) single-phase live output.
DO 3E	H88	7.1 (phase) 7.2(neutral)	0	Not set	230Vac, 50Hz, 2A (AC1) single-phase live output.
DO 4E	H89	8.1 (phase) 8.2(neutral)	0	Not set	230Vac, 50Hz, 2A (AC1) single-phase live output.
DO 5E	H90	9.1 (phase) 9.2(neutral)	0	Not set	230Vac, 50Hz, 2A (AC1) single-phase live output.

GI terminal block

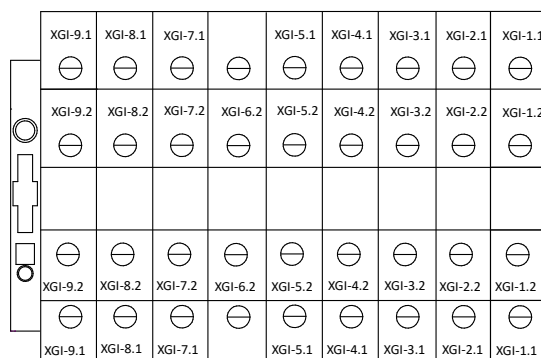

17.2 MANAGEMENT OF SECONDARY CIRCULATOR/RELAUNCH PUMP (WITH ROOM THERMOSTAT)

It allows the management of a secondary or booster circulator to serve the plant.

A room thermostat (N.C.) must be configured appropriately.

- Thermostat closed contact -> The secondary circulator is activated;
- Thermostat open contact -> The secondary circulator is off with a delay given by P02 (post-pumping).

I/O Resource - Parameter	Value	Function	XGI terminals
ID9E can be activated via H63	19	Room thermostat	4.1 / 4.2
DO5E can be activated via H90	43	Secondary circulator	9.1 (phase) 9.2(neutral)

The temperature control of the Heat pump is independent from the thermostat call.
When the Heat pump is Off, the booster circulator will be off regardless of the thermostat call.

17.3 MIXER VALVE MANAGEMENT

The mixer valve is regulated by means of specific PID which strives to maintain the delivery temperature of the radiant panel at the set value.

The setpoint setting can be found in the 'Set' Menu:

rCoo = Mixer flow temperature setpoint in cooling mode = 15°C (default)

rHea = Mixer flow temperature setpoint in heating mode = 30°C (default)

The resources and the parameters to be setting are the following:

I/O resource - Parameter	Description	Value	Function	XGI terminals
ST 5E can be activated via H27	Analogue input	44	Mixer probe	1.1 / 1.2
ID9E can be activated via H63	Digital input	19	Room thermostat	4.1 / 4.2
DO1E can be activated via H86	Voltage output	34	Valve open command	5.1 (phase) / 6.2(neutral)
DO2E can be activated via H87	Voltage output	35	Valve close command	5.2 (phase)
DO3E can be activated via H88	Voltage output	33	Mixer pump	7.1 / 7.2
i01	Valve opening time	Recover the value from the technical data supplied installed		
i02	Interval between two interruptions	30 seconds ¹		
i03	PID proportional band	2°C ²		
i04	PID integral time	300 seconds ³		
i05	PID derivative time	0 ⁴		
i06	Mixer management only active in heating mode	1		
	Mixer management only active in cooling mode	2		
	Mixer management only active in heating and cooling mode	3		

¹Recommended value. Time interval between one correction and the next.

²Recommended value. Intervention area defined by the difference between the setpoint for the mixer flow and the temperature measured by mixing flow probe.

³Recommended value. Time taken by the mixing valve to switch from open to closed and vice versa, when the difference between setpoint set for the flow of the mixing valve and the value read by the mixing probe is greater than or equal to proportional band. The more larger this value, the slower the change in approach to the setpoint set for the mixing valve flow.

⁴Derivate component of regulation; use only if you have a good knowledge of regulator logic.

17.3.1 Determination of setpoint

The setpoint on which to perform regulation is given by rCOO or rHEA respectively in cooling and heating mode. If dynamic compensation of the setpoint is enabled (b08=1), then the setpoint will be corrected the same way as the heat pump/chiller.

The maximum and minimum value reached by the compensation are not controlled. Therefore the parameters must be configured so that the setpoints are not brought to unwanted values outside of the allowed work ranges.

17.3.2 Mixing pump

The mixing pump (DO3E) switches on when there is a call from the digital input ambient thermostat (ID9E) and switches off with a delay of P02 from the instant the thermostat call ceases.

17.4 SOLAR INTEGRATION MANAGEMENT

To enable the function, set S01=1.

Parameter	Description	Value	Function	XGI terminals
ST6E can be activated via H28	Analogue input	39	Solar storage tank probe	2.1 / 2.2
ST7E can be activated via H29	Analogue input	38	Solar collector probe	2.1 / 2.2
DO3E can be activated via H88	Live output	30	Solar circulator	7.1 (phase) 7.2(neutral)
DO4E can be activated via H89	Live output	45	Solar exhaust valve	8.1 (phase) 8.2(neutral)

17.4.1 Activation of solar circulator

Solar management is also active with the unit off.

The solar circulator is active in both of the following conditions are met:

- The temperature of the solar collector is higher than that defined by parameter **S13** (default 40°C), the solar circulator is activated;
- The temperature difference between the solar collector and that of the solar storage tank is higher than the parameter **S02** (default 6°C).

17.4.2 Collector protection

If the temperature of the collector exceeds parameter **S04** (default 110°C), the solar circulator is periodically on intermittently with the times set in:

- **S05** = time ON (default 15 seconds);
- **S06** = time OFF (default 15 seconds).

As hysteresis to exit the protection condition use **S08** (default 2°C).

This protection is guaranteed even with the machine Off.

17.4.3 Collector overtemperature alarm

If the collector probe exceeds the value of parameter **S12** (default 130°C), there is an alarm condition **E10** which blocks the solar circulator. The hysteresis to return from the alarm condition is given by parameter **S08** (default 2°C).

If an alarm is triggered, operation of the heat pump is guaranteed.

17.4.4 DHW overtemperature alarm

If the temperature of the DHW storage tank exceeds the parameter **S10** (default 80°C), the alarm **E50** is triggered.

The hysteresis to return from the alarm condition is given by parameter **S11** (default 2°C).

If an alarm is triggered, operation of the heat pump is guaranteed.

17.4.5 Solar exhaust valve

If alarms **E10** and **E50** are triggered simultaneously, the solar exhaust valve will be activated.

It is recommended to connect the output of terminals 8.1 (phase) – 8.2 (neutral) to a timed relay to manage the flow of the exhaust valve. If any doubts arise, contact our headquarters.

17.4.6 Disposal of solar tank heat

The solar circulator runs to dissipate excess heat in the storage tank by exploiting the solar collector if both of the following conditions are met:

- The temperature of the DHW storage tank is higher than parameter S15 (default 60°C);
- The temperature of the solar collector is lower than 35°C (parameter S13 – parameter S14).

The solar collector is off when at least one of the following conditions is met:

- The temperature of the DHW storage tank is lower than parameter S15 (default 60°C).
- The temperature of the collector exceeds the parameter S13 (default 40°C), as conditions are no longer in place for proper dissipation of the heat.

17.4.7 Antifreeze

Function active if the parameter **S01** = 1.

If the temperature of the solar collector is lower than parameter **S07** (default 5°C), the solar circulator is activated in antifreeze mode.

This protection is only enabled with the machine Off.

The function is inhibited if the temperature of the DHW storage tank is lower than the value defined in parameter **S16** (default 20°C).

This regulator also works with the unit Off.

Setting the parameter **S01** = 2, the antifreeze function is never active (for example because the solar plant is supplied with glycol).

Be careful as enabling this function could damage the entire system.

Note:

- Solar integration is NOT managed if the controller of the unit is OFF.
- The remote digital input OFF has no effect on solar management.
- During first ignition, check that the probe of the solar collector measures a temperature lower than 160°C and that this temperature corresponds to that read on the controller of the internal unit.
- Solar circulator live output 230V ac, 50Hz, 2A (AC1).
- For higher absorptions, connect the output to the contactor coil.
- Factory-set parameters for solar management, any other configurations are the responsibility of the user and/or installer. The company excludes any contractual and extra contractual liability for damage caused to persons, animals or objects, by incorrect installation, setting and maintenance, improper use of the equipment, and the partial or superficial reading of the information contained in this manual.

18. TABLES OF PERMITTED SETUPS FOR USER AND INSTALLER

	CAUTION:
	All the operations with INSTALLER visibility must be carried out by QUALIFIED PERSONNEL.
	Not all of the configurations can be activated and/or modified at the same time.
	Values other than the default values can jeopardise proper operation of the unit. If in doubt on which value to set, contact our headquarters.
	The company excludes any contractual and extra contractual liability for damage caused to persons, animals or objects, by incorrect installation, setting and maintenance, improper use of the equipment, and the partial or superficial reading of the information contained in this manual.

We shall not be held liable for any breakage or malfunctioning caused by third parties changing the default parameters if not expressly authorised to do so.

The following is the table of the allowed configurations; not all of them can be selected simultaneously.

Values other than the default values can jeopardise proper operation of the unit. If in doubt on which value to set, contact our headquarters.

Parameter	Description	Unit	Default	Range	Visibility	Allowed configurations:	
						Description	Notes
Coo	First cooling setpoint	°C	7.0	25÷Coo2	U		
Hea	First heating setpoint	°C	45.0	Hea2÷H01	U		
San	Sanitary setpoint	°C	48.0	25÷H01	U		If sanitary function active. See par. 10.2
Coo2	Second cooling setpoint	°C	18.0	Coo÷25	U		
Hea2	Second heating setpoint	°C	35.0	25÷Hea	U		
*rCOO	Mixing valve summer setpoint	°C	15.0	-50÷80	I		Config if Gi accessory present
*rHEA	Mixing valve winter setpoint	°C	30.0	-50÷80	I		Config if Gi accessory present
San2	Second sanitary setpoint	°C	45.0	0÷80	I		
H01	Maximum heating setpoint	°C	60.0	-50÷80	I		
H04	Mnimum cooling setpoint	°C	5.0	-50÷80	I		
H10	Sanitary function enabling	/	0	0÷6	I	See par. 10.2	
H17	Input configuration Analogue ST6	/	0	0÷49	I	0 = Input disabled 6 = Domestic hot water probe	
H18	Input configuration Analogue ST7	/	0	0÷49	I	0 = Input disabled 41 = Remote water temperature probe	
H22	0-10vDC live input configuration Analogue ST11	/	0	0÷49	I	0 = Input disabled 40 = Plant setpoint decalibration	
*H27	Input configuration Analogue ST5E	/	0	0÷49	I	0 = Input disabled 44 = Mixer probe	Only if Gi accessory present
*H28	Input configuration Analogue ST6E	/	0	0÷49	I	0 = Input disabled 39 = Solar storage tank probe	Only if Gi accessory present
*H29	Input configuration Analogue ST7E	/	0	0÷49	I	0 = Input disabled 38 = Solar collector probe	Only if Gi accessory present
*H30	Input configuration Analogue ST8E	/	0	0÷49	I		Only if Gi accessory present
H46	Input configuration Digital ID2	/	0	0÷30	I	0 = Input disabled 3 = Summer/winter mode change	
H47	Input configuration Digital ID3	/	2	0÷30	I	0 = Input disabled 2 = Remote On / Off	
H53	Input configuration Digital ID9	/	0	0÷30	I	0 = Input disabled 21 = Hz min/max remote 25 = Silenced version 26 = Double set-point call 28 = DHW thermostat call	
*H60	Input configuration Digital ID6E	/	0	0÷30	I		Only if Gi accessory present
*H61	Input configuration Digital ID7E	/	0	0÷30	I		Only if Gi accessory present
*H62	Input configuration Digital ID8E	/	0	0÷30	I		Only if Gi accessory present
*H63	Input configuration Digital ID9E	/	0	0÷30	I	0 = Input disabled 19 = room thermostat	Only if Gi accessory present
H75	Digital inputs polarity	/	0	0÷255	I	0 = Digital inputs N.A. 1 = ID1 polarity inverted 2 = ID2 polarity inverted 4 = ID3 polarity inverted 8 = ID4 polarity inverted 16 = ID5 polarity inverted 32 = ID6 polarity inverted 64 = ID7 polarity inverted 128 = ID8 polarity inverted	
H76	Digital inputs polarity	/	0	0÷255	I	0 = Digital inputs N.A. 1 = ID9 polarity inverted 2 = ID10 polarity inverted 4 = ID1E1 polarity inverted 8 = ID2E1 polarity inverted 16 = ID3E1 polarity inverted 32 = ID4E1 polarity inverted 64 = ID5E1 polarity inverted 128 = ID6E1 polarity inverted	
H81	Output configuration In DO3 power	/	22	0÷48	I	0 = Output disabled 22 = Plant integration heater 26 = DHW integration heater	
H82	Output configuration In DO4 power	/	14	0÷48		0 = Output disabled = Resistenza scambiatore	
H83	Output configuration In DO5 power	/	28	0÷48		0 = Output disabled = Base resistance	

Parameter	Description	Unit	Default	Range	Visibility	Allowed configurations:	Notes
						Description	
H84	Output configuration In DO6 power	/	6	0÷48	I	0 = Output disabled 6 = DHW valve	
H85	Output configuration In DO7 power	/	25	0÷48	I	0 = Output disabled 25 = Double set-point valve 29 = Boiler enabling 24 = Alarm warning 31 = Summer/winter operating mode warning 21 = Defrost warning 47 = Machine block warning	
*H86	Output configuration In voltage DO1E	/	0	0÷48	I	0= Output disabled 34= Valve opening command	Only if Gi accessory present
*H87	Output configuration In voltage DO2E	/	0	0÷48	I	0= Output disabled 35= Valve closing command	Only if Gi accessory present
*H88	Output configuration In voltage DO3E	/	0	0÷48	I	0 = Output disabled 30 = Solar circulator	Only if Gi accessory present
*H89	Output configuration In voltage DO4E	/	0	0÷48	I	0 = Output disabled 45 = Solar exhaust valve	Only if Gi accessory present
*H90	Output configuration In voltage DO5E	/	0	0÷48	I	0 = Output disabled 43 = Secondary circulator	Only if Gi accessory present
H100	Digital output polarity	/	2	0÷255	I	0 = Digital inputs N.O. 1 = Inverted polarity of DO1 2 = Reversed polarity of DO2 4 = Reversed polarity of DO3 8 = Reversed polarity of DO4 16 = Reversed polarity of DO5 32 = Reversed polarity of DO6 64 = Reversed polarity of DO7 128 = Reversed polarity of DOE1	To reverse more than one polarity, do the sum of those you want to invert
H101	Digital output polarity	/	0	0÷255	I	0 = Digital inputs N.A. 1 = Reversed polarity of DO2E 2 = Reversed polarity of DO3E 4 = Reversed polarity of DO4E 8 = Reversed polarity of DO5E 16 = Reversed polarity of DO6E 32 = Reversed polarity of DO7E	To reverse more than one polarity, do the sum of those you want to invert
H124	Serial baud rate	baud	1	0÷3	I	0=4800 baud 1=9600 baud 2=19200 baud 3=38400 baud	
H125	Serial parity	/	2	0÷3	I	0=none parity, 2 stop bits 1=odd parity, 1 stop bit 2=even parity, 1 stop bit 3=none parity, 1stop bit	
H126	Serial address	/	1	0÷200	I	In the cascade configuration, assign a different address to each controller.	
H129	Enable second setpoint	/	0	0÷4	I		
H130	Heating with DHW storage tank	/	0	0÷1	I	0 = Normal operation 1 = In Heating, machine always turned towards DHW	
H136	OFF state deactivation with ID presence ON/OFF remote	/	0	0÷1	I		
H138	Enabling second set point for DHW	/	0	0÷4	I		
H141	Priority communication channels Modbus	/	1	0÷1	I	0 = Priority on channel 1 (CN14) 1 = Priority on channel 2 (CN12-N13)	
H142	MODBUS 2 serial baud rate (CN12 - CN13)	/	1	0÷3	I	0 = 4'800 Baud 1 = 9'600 Baud 2 = 19'200 Baud 3 = 38'400 Baud	
H143	Parity and Stop Bit serial MODBUS	/	2	0÷3	I	0 = No parity, 2 Stop bits 1 = ODD Parity, 1 Stop Bit 2 = EVEN parity, 1 Stop Bit 3 = No parity, 1 Stop Bit	
H144	Serial address for MODBUS	/	0	0÷127	I	0 = same address as Serial Mocbus 1 (H126)	
A08	Antifreeze alarm activation setting	°C	3	-127÷127	I	Different values can jeopardise proper operation of the unit	
b01	Compressor band in cold regulation	°C	2	0,5÷5,0	I		
b02	Compressor band in hot regulation	°C	2	0,5÷5,0	I		
b04	Radiant panels valve switching time	sec	30	0÷600	I	Different values can jeopardise proper operation of the unit	
b06	Sanitary valve stroke time	sec	45	0÷255	I		

Parameter	Description	Unit	Default	Range	Visibility	Allowed configurations:	
						Description	Notes
b08	Enable dynamic setting	/	0	0÷1	I		
b09	Maximum cooling offset	°C	3.0	-50.0÷80.0	I		
b10	Maximum heating offset	°C	-3.0	-50.0÷80.0	I		
b11	Cooling outdoor temperature setting	°C	25	-127÷127	I		
b12	Heating outdoor temperature setting	°C	15	-127÷127	I		
b13	Cooling temperature delta	°C	-10.0	-50.0÷80.0	I		
b14	Heating temperature delta	°C	10.0	-50.0÷80.0	I		
b15	0-10V analogue input setting decalibration band	°C	5.0	0.0÷10.0	I		
b21	System water reversing valve switching time	sec	0	0÷600	I		
b22	Plant probe temperature control cut-off hysteresis	°C	5.0	0.0÷25.5	I		
b24	Maximum ΔT_{set} for compressors restart	°C	8.0	0.0÷25.5	I		
b25	Compressor cut-on hysteresis	°C	2.0	0.0÷25.5	I		
b30	Enabling compressor switch-off with room call satisfied	-	0	0÷1	I	0 = function disable 1 = function active	
P01	Pump ON compressor ON delay	sec	30	0÷255	I		
P02	Pump OFF compressor OFF delay	min	2.0	0÷25.5	I		
P03	Pump operating mode	/	0	0÷1	I		The pump is always on if the antifreeze heaters are active.
P04	Pump setting in antifreeze	°C	5	-15÷15	I		
P05	Pump hysteresis in antifreeze	°C	2.0	0.0÷15.0	I		
P06	Set delta T water pump in heating	°C	4°C	0÷255	I		
P07	Maximum pump speed	%	95%	65÷95	I		
P08	Minimum pump speed	%	75%	50÷95	I		
P09	Modulating pump inlet/outlet water delta T setting	°C	2.0	0÷15	I		
P16	Interval between 2 periodical activations of the pump	min	0	0÷600	I		
P17	Operating time of the pump in periodical mode	sec	0	0÷255	I		
r02	Antifreeze heaters setpoint in heating mode	°C	4	3÷6	I		Only change in the presence of glycol water. Contact our headquarters.
r03	Antifreeze heaters setpoint in cooling mode	°C	4	3÷6	I		Only change in the presence of glycol water. Contact our headquarters.
r06	Antifreeze heaters delta	°C	2.0	0.0÷25.5	I		Only change in the presence of glycol water. Contact our headquarters.
r08	Operation in substitution upper limit	°C	-20	-20÷50	I	Respect r22 ≥ r28 ≥ r08	Do not modify this value, as it could jeopardise operation of the unit
r09	Hysteresis for heat pump blockage	°C	1,0	0,0 ÷10,0			
r10	Plant integration enabling	/	0	0÷1	I	0 = Function disabled 1 = Function enabled	
r11	Plant integration heater delta	°C	0.5	0,0÷25.5	I		
r12	Plant/heat pump integration heater activation delay	min	10	0÷255	I		
r14	Compressor bypass on system with sanitary heating element active	/	0	0÷1	I	r14 = 1 during activation of the sanitary heating elements is not permitted the use of plant-side compressors is not permitted	
r15	DHW integration enabling	/	0	0÷2	I	0 = Function disabled 1 = Function enabled	

Parameter	Description	Unit	Default	Range	Visibility	Allowed configurations:	
						Description	Notes
r16	DHW/heat pump integration heater activation delay	min	15	0÷255	I		
r19	Duration of tray heater activation since last defrost	min	10	0÷255	I	0= heater activation regardless of defrost.	
r21	Enables plant side mitigation with heaters in defrost mode	/	0	0÷1	I	0= Function disabled 1= Function enabled	
r22	Joint operation bracket I upper limit	°C	7	-16÷50	I	Respect r22 ≥ r28 ≥ r08	Do not modify this value, as it could jeopardise operation of the unit
r23	Type of use of boiler	/	6	0÷6	I		
r24	Type of use of integration heaters	/	3	0÷3	I		
r25	Disinfection setpoint	°C	80	0÷100	I		
r26	Disinfection duration	min	12	0÷255	I		
r27	Heat pump setpoint in disinfection	°C	55.0	-500÷800	I		
r28	Joint operation bracket II upper limit	°C	-7	-16÷50	I	Respect r22 ≥ r28 ≥ r08	Do not modify this value, as it could jeopardise operation of the unit
r29	First setpoint temperature offset for boiler and plant heaters (HEA)	°C	0	0÷100	I		
r30	Second setpoint temperature offset for boiler and plant heater (HEA2)	°C	0	0÷100	I		
r31	Temperature offset for boiler and DHW heaters (SAN)	°C	0	0÷100	I		
r32	Boiler supply	/	1	0÷3	I		
r33	Pump management with heaters active	/	3	0÷3	I		
r34	Disinfection day	/	0	0÷7	U	0 = Disabled 1 = Monday 2 = Tuesday 3 = Wednesday 4 = Thursday 5 = Friday 6 = Saturday 7 = Sunday	
r35	Disinfection time (minute of the day)	/	0	0÷1439	U		
r36	Anti-loop time on sanitary operation	min	1	0÷255	I		Control to prevent the machine remain in sanitary production indefinitely because does not reach the set point. Control active if parameter R36 is different from 0. In this case, the time of r36 is counted since the compressor started to work in the DHW mode. If the production of the DHW is not finished within r36 minutes, then you exit forced out of sanitary production.
r37	Boiler operation in cooling + DHW mode	/	1	0÷2	I	0 = Boiler not used 1 = Boiler used in integration 2 = Boiler does DHW and PDC does plant.	
r38	Heat pump blockage threshold for high T	°C	46	-127÷127	I		
r39	Heat pump blockage threshold for high Text in heat	°C	46	-127÷127	I		
b24	Maximum compressor cut-on delta	°C	8	0÷25,5			
b24	Compressor cut-on delta	°C	2	2,0÷25,5			

Parameter	Description	Unit	Default	Range	Visibility	Allowed configurations:	
						Description	Notes
d04	Defrost output pressure	bar	24.0	-500÷800	I		
d08	Minimum time between defrost and next	min	35	0÷255	I		
L02	User enablement for min./max. Hz function	/	0	0÷1	I		
L03	Active min./max. Hz	/	0	0÷7	I		
s01	Solar thermal enabling	/	0	0÷2	I		
s02	Solar ΔT	°C	0	0÷25.5	I		
s03	Solar hysteresis	°C	0	0÷25.5	I		
s04	Maximum solar temperature	°C	0	0÷255	I		
s05	Pump on time in maximum solar temperature	sec	0	0÷255	I		
s06	Pump off time in max. solar temp	sec	0	0÷255	I		
s07	Solar antifreeze set	°C	0	-127÷127	I		
s08	Solar antifreeze hysteresis	°C	0	0÷25.5	I		
s09	Constant for calculating solar power output	/	0	0÷999	I		
s10	Maximum solar DHW storage temperature threshold	°C	0	0÷255	I		
s11	Solar sanitary hysteresis	°C	0	0÷25.5	I		
s12	Solar collector overfill alarm threshold	°C	0	0÷255	I		
s13	Minimum temperature threshold collector for activation solar	°C	0	0÷255	I		
s14	Hysteresis for sanitary cooling	°C	0	0÷25.5	I		
s15	Sanitary cooling threshold	°C	0	0÷255	I		
s16	Minimum temperature threshold collector anti-freeze storage	°C	0	0÷255	I		
L02	User enablement for min./max. Hz function	/	0	0÷1	I		
L03	Active min./max. Hz	/	0	0÷7	I		
*i01	Valve opening time	sec	0	0÷600	I		
*i02	Interval between two corrections	sec	0	0÷600	I		
*i03	PID proportional band		0	0÷80.0	I		
*i04	PID integral time	sec	0	0÷2000	I		
*i05	PID derivative time	sec	0	0÷25.5	I		
*i06	Radiant panel configuration	/	0	0÷3	I		
Ac09	Flow-meter minimum water flow rate	l/min	0.0	0÷100	I	See par. "Flowmeter"	
Ac10	Flowmeter outlet at the minimum flow rate	Volt	0.0	0÷100	I		
Ac11	Maximum flowmeter flow rate (0106, 0109)	l/min	50.0	0÷800	I		
	Maximum flowmeter flow rate (0112, 0115, 0118)		85.0	0÷800			
Ac12	Flow meter outlet at the maximum flow rate	Volt	0.0	0÷100	I		

(*) If Gi module is present

19. ALARMS

By placing the controller in OFF mode, the alarms reset and the counts of the relative hour interventions are also reset. If the alarms are still triggered when switching the unit back on, contact technical assistance. The values indicated below could be subject to updates. If you have any doubts, contact our headquarters.

19.1 [E006] FLOWMETER

The water side flowmeter is already installed inside the unit and MUST NOT be tampered with or bypassed in any way. The flow switch is bypassed for 10 seconds after the unit is switched on. When the bypass time has elapsed, you must evaluate the status of the digital input, if active, the flow is considered present.

If the flow is found to be missing for **5 seconds**, the alarm is triggered and the circulator switches on for **120 seconds**.

If the alarm triggers more than 3 times an hour, it must be reset manually.

The alarm does not trigger in the following conditions:

- During domestic hot water production;
- During the plant venting cycle function.

19.2 [E018] HIGH-TEMPERATURE

If the water delivery probe detects a value higher than **65°C** for longer than **50** seconds, the alarm is active only in chiller mode. It deactivates when the temperature returns below **62°C**.

19.3 [E020] INCONGRUENT PRESSURES

For compressor enabled for more than **150** seconds, the suction pressure probe detect a pressure higher than the condensation pressure probe, the alarm displayed is **E020**. The alarm is not resettable (it is necessary to cut the power supply to eliminate the alarm).

This alarm is not in defrosting mode.

19.4 [E005] ANTIFREEZE

If the outlet water probe has a value lower than **A08 (3°C)**, the alarm is active. It deactivates if the temperature recorded by the probe is higher than **+6°C**. The alarm is bypassed for **120** seconds from switch on in heating mode.

19.5 [E611÷E681] PROBE ALARMS

The alarm is triggered if any connected or enabled probe is short-circuited or interrupted.

The alarm also triggers if the upper limit (**100°C**) or the lower limit (**-50°C**) of the probes is exceeded. A probe figured as sanitary probe will not trigger any alarms if domestic hot water is not enabled.

NOTE:

If the pressure switch on the machine detects a pressure exceeding **30,5 bar** the driver and the compressor are powered off and probe error E641 is displayed (Compressor discharge probe fault).

The alarm is cleared when the pressure drops below **23 bar**.

19.6 [E801] TIMEOUT INVERTER

When the machine's controller does not communicate with the driver board of the compressor, a timeout alarm is triggered to avoid losing control of the system.

19.7 [E851 ÷ E971] INVERTER

The inverter has its own list of alarms.

19.8 [E00] REMOTE ON/OFF (WARNING)

If the unit is controlled by a remote digital input. See par. 10.4.1

19.9 [E001] HIGH-PRESSURE

If the pressure transducer on the unit detects a pressure higher than **30,3 bar** the alarm is triggered.

In this case the compressor is blocked immediately. The alarm is reset when the pressure drops below **21,3 bar**. If the alarm triggers more than 3 times an hour, it must be reset manually.

19.10 [E002] LOW-PRESSURE

In chiller mode, if the pressure transducer on the unit detects a pressure lower than **1,7 bar**, the alarm is triggered.

In heat pump mode, if the pressure transducer on the unit detects a pressure lower than **0,7 bar**, the alarm is triggered.

The alarm is reset when the pressure rises **2.0 bar** above the triggering threshold.

A bypass time of 60 seconds is counted every time the compressor is activated.

When the alarm is triggered, it blocks the compressors of the circuit. The alarm is reset manually if it triggers 3 times an hour.

19.11 [E008] DRIVER LIMITATION

If the compressor does not reach the speed at the intended ramp value within **30** minutes, the alarm is triggered and the compressor switches off for safety purposes.

The alarm is reset manually if it triggers 3 times an hour.

19.12 [E041] 4-WAY VALVE

Manually reset alarm, it identifies malfunctioning of the 4-way reversing valve.

The alarm does not trigger for a bypass time of approximately 180 seconds from start-up of the compressor.

- In heating and sanitary mode, the alarm is triggered when, the bypass time having elapsed, the water delivery temperature is lower than the water return temperature of the heat pump - 1°C.
- In cooling mode, the alarm is triggered when, the bypass time having elapsed, the water delivery temperature is higher than the water return temperature of the heat pump + 1°C.

19.13 POWER FAILURE

When restored:

- The instrument goes back to the condition it was in prior to the power failure
- If a defrost cycle is in progress, it is cancelled
- All of the timers in progress are cancelled and reinitialized

19.14 UTILITIES BLOCK ALARM TABLE

Code	DESCRIPTION	Block
E00	Remote off	Machine
E001	High pressure alarm	Machine
E002	Low pressure alarm	Machine
E005	Antifreeze alarm	Machine
E006	Flow alarm	Machine
E008	Forced compressor shutdown for lack of lubrication	Machine
E009	Discharge high temperature alarm	Machine
E010	Solar collector high temperature alarm	Solar pump
E018	Cooling high temperature alarm	Machine
E020	Inverted trasductors pressure alarm	Machine/sanitary
E041	Incongruent temperature alarm	Machine
E050	DHW storage tank high temperature alarm	-
E101	Communication timeout with Slave 1	Machine
E611	Water inlet probe failure	Machine
E621	Water outlet probe failure	Machine
E631	Compressor intake probe failure	Machine
E641	Compressor discharge probe fault / high pressure switch trip	Machine
E651	Outdoor air probe failure	Machine
*E652	Mixer probe failure	Machine
E661	DHW probe failure	Machine
*E662	Solar storage tank probe failure	Machine
E671	Plant remote probe failure	Machine
*E672	Solar collector probe failure	Machine
E691	Low pressure transducer failure	Machine
E701	High pressure probe failure	Machine
E711	Voltage input failure 0-10V DC	Machine
E801	Inverter timeout	Compressor
E821	IPM module overcurrent	Compressor
E831	PFC module overheating	Compressor
E841	Inverter abnormal voltage DC Bus side	Compressor
E851	Inverter Hardware problem	Compressor
E861	Inverter current too high	Compressor
E871	High temperature IPM module	Compressor
E881	Supply voltage out of limits	Compressor
E891	One or more compressor supply phases absent	Compressor
E901	Inverter model error	Compressor
E911	Inverter overload error	Compressor
E921	Inverter PFC module overcurrent	Compressor
E931	Internal communication error	Compressor
E941	PFC model fault	Compressor
E951	Inverter board probe error	Compressor
E961	Abnormal condition	Compressor
E971	EEPROM error	Compressor
E981	High pressure inverter	Compressor

(*) If Gi module present

20. MODBUS VARIABLES

The controller is configured as follows by default:

BAUD RATE	9600
PARITY	EVEN
DATA BIT	8
STOP BIT	1
DEVICE ID	1

To configure the Modbus communication according to your requirements, you must modify the following logs:

H124 : BAUD RATE	
0	4800
1	9600
2	19200
3	38400

H125 : PARITY, STOP BIT	
0	NONE, 2 bit
1	ODD, 1 bit
2	EVEN, 1 bit
3	NONE, 1 bit

H126 : DEVICE ID	1 ÷ 200
------------------	---------

Modbus comands:

READING	HOLDING REGISTER
WRITING	6-16

Register	Format	Bit	R/W	Range	Name	Description	Note
1	INT	-	R	-	Firmware information	Firmware version	
2	INT	-	R	-		Firmware release	
3	BYTE (H)	-	R	-		Firmware sub-release	
	BYTE (L)	-	R	-		Firmware creation day	
4	BYTE (H)	-	R	-		Firmware creation month	
	BYTE (L)	-	R	-		Firmware creation year	
80 ÷ 97	ASCII	-	R	-	Serial number	Registration number	
444	INT	-	R	0 ÷ 800	Water flow rate		
1089	INT	-	R/W	1 ÷ 200	Serial address	Modbus serial ID	
200	INT	-	R	-	Machine settings	(0) Stand by	Reading values of the machine status
		-	R	-		(1) Cooling	
		-	R	-		(2) Heating	
		-	R	-		(4) Only sanitary mode ¹	
		-	R	-		(5) Cooling + Sanitary ¹	
		-	R	-		(6) Cooling + Sanitary ¹	
7201	BIT MASK	0	R/W	-	Enablement of writing the machine status remotely	Necessary for the operation of the reg. 7200.	
7200	INT	-	W	-	Machine settings	(0) Stand by	The writing values that are not allowed at this address can lead to unexpected operations, so keep only those values that are allowed in writing.
		-	W	-		(1) Cooling	
		-	W	-		(2) Heating	
		-	W	-		(4) Only sanitary ¹	
		-	W	-		(5) Cooling + Sanitary ¹	
		-	W	-		(6) Heating + Sanitary ¹	
7201	BIT MASK	1	R/W	-	Enablement of writing the machine status remotely	Necessary for the operation of the reg. 7203/7208.	
7203	°C/10	-	R/W	5.0 ÷ 23.0	Setpoint	Cooling	
7204	°C/10	-	R/W	25.0 ÷ 55.0		Heating	
7205	°C/10	-	R/W	25.0 ÷ 55.0		Sanitary	
7206	°C/10	-	R/W	5.0 ÷ 23.0		Second cooling	
7207	°C/10	-	R/W	25.0 ÷ 55.0		Second heating	
7208	°C/10	-	R/W	0.0 ÷ 80.0		DHW preparer	
7201	BIT MASK	2	R/W	-		Enabling the switching to the second setpoint	Necessary for the operation of bit 0 of reg. 7202.
7202	BIT MASK	0	W	-	0=primary setpoints, 1=secondary setpoint	Writing value	
7217	BIT MASK	0	R	-	0=primary setpoints, 1=secondary setpoint	Reading value	
7201	BIT MASK	3	R/W	-	Room temperature call	Enablement of remote room call writing	Necessary for the operation of bit 1 of reg. 7202.
7202	BIT MASK	1	R/W	-		Forced room temperature call remotely	
7201	BIT MASK	4	R/W	-	Sanitary call	Enablement of remote sanitary call writing	Necessary for the operation of bit 1 of reg. 7202.
7202	BIT MASK	2	R/W	-		Forced remote sanitary mode call	
7201	BIT MASK	5	R/W	-	Anti-Legionella ²	Enablement of anti-legionella cycle remotely	Necessary for the operation of bit 3 of reg. 7202.
7202	BIT MASK	3	R/W	-		Remote anti-legionella cycle request activation	The bit must be 1 for the entire cycle period.
7216	BIT MASK	5	R	-		Anti-legionella cycle in progress	
		6				Anti-legionella cycle failed or stopped	It remains at 1 until the next cycle, or it resets itself when the board is turned off.
7202	BIT MASK	5	R/W	-	Plant air-vent	Forced plant air-vent	Only if the machine is in Stand By (0).
7202	BIT MASK	6	R/W	-	Sanitary disablig	Sanitary call prohibition (without exiting from the actual mode + SAN function)	Active only if the setting of bit 3 is 7201 (when the room temp. call is also managed remotely).

Register	Format	Bit	R/W	Range	Name	Description	Note
7202	BIT MASK	7	R/W	-	Defrosting	Forced defrosting	Only if the machine is in heating (2-6).
7214	BIT MASK	13	R	-		Defrosting on call	
		14				Defrosting in progress	
8000	kW/100	-	R	-	Power ⁶	Thermal power output	Estimated value in the absence of a flow meter
8001	kW/100	-	R	-		Compressor power consumption	
8002	kW/100	-	R	-		Circulator power consumption	
8003	kW/100	-	R	-		Fan power consumption	
8004	kW/100	-	R	-		Total power consumption	
8005	kWh/10	-	R	-	Energy ⁶	Energy consumed yesterday in cooling	Values present only with heat pump combined with i-CR, e-LITE or Hi-T2 controllers
8006	kWh		R			Energy consumed last month in cooling	
8007	kWh*10		R			Energy consumed last year in cooling	
8008	kWh/10		R			Energy yielded yesterday in cooling	
8009	kWh		R			Energy yielded last month in cooling	
8010	kWh*10		R			Energy yielded last year in cooling	
8011	kWh/10	-	R	-		Energy consumed yesterday in heating	
8012	kWh		R			Energy consumed last month in heating	
8013	kWh*10		R			Energy consumed last year in heating	
8014	kWh/10		R			Energy yielded yesterday in heating	
8015	kWh		R			Energy yielded last month in heating	
8016	kWh*10		R			Energy yielded last year in heating	
239	BYTE (H)	-	R	-		SG-Ready	(0) Smart grid management not active
	BYTE (H)	-	R	-	(1) Smart grid logics enabled		
	BYTE (L)	-	R	-	(0) SG-00		
	BYTE (L)	-	R	-	(1) SG-01		
	BYTE (L)	-	R	-	(2) SG-10		
	BYTE (L)	-	R	-	(3) SG-11		
305	ora	-	R	-	Operating hours	Compressor 1	
307	ora	-	R	-		Compressor 2	
309	ora	-	R	-		Compressor 3	
313	ora	-	R	-		Compressor 1 circuit 2	
315	ora	-	R	-		Compressor 2 circuit 2	
317	ora	-	R	-		Compressor 3 circuit 2	
253	°C/10	-	R	-	Temperature transducer	Evaporation	
254	°C/10	-	R	-		Condensation	
626	°C/10	-	R	-		Evaporation circuit 2	
627	°C/10	-	R	-		Condensation circuit2	
400	°C/10	-	R	-	Temperature ³	Water inlet	
401	°C/10	-	R	-		Water outlet	
405	°C/10	-	R	-		DHW	
422	°C/10	-	R	-		Compressor inhalation	
428	°C/10	-	R	-		Outdoor	
433	°C/10	-	R	-		Compressor discharge 1	
434	°C/10	-	R	-		Compressor discharge 2	
435	°C/10	-	R	-		Compressor discharge 3	
437	°C/10	-	R	-		Solar collector	
438	°C/10	-	R	-		Solar accumulation	
440	°C/10	-	R	-		Plant remote	
443	°C/10	-	R	-		Radiant panels mixing delivery	
447	°C/10	-	R	-		DHW preparer recirculation	
20422	°C/10	-	R	-		Compressors inhalation (circuit 2)	
20433	°C/10	-	R	-		Compressor 1 discharge (circuit 2)	
20434	°C/10	-	R	-		Compressor 2 discharge (circuit 2)	
20435	°C/10	-	R	-		Compressor 3 discharge (circuit 2)	

Register	Format	Bit	R/W	Range	Name	Description	Note					
406	bar/100	-	R	-	Pressions ³	High pressure						
414	bar/100	-	R	-		Low pressure						
20406	bar/100	-	R	-		Circuit 2 high pressure						
20414	bar/100	-	R	-		Circuit 2 low pressure						
7000	%/10	-	R	-	Analogue output	Condensation fan						
7001	%/10	-	R	-		Circulating pump						
628	%/10	-	R	-		Condensation fan circuit 2						
950	BIT MASK	0	R	-	Alarms ^{4 5}	High pressure	E001					
		1				Low pressure	E002					
		2				Compressor thermal protection	E003					
		3				Fan thermal protection	E004					
		4				Frost	E005					
		5				Lack of flow	E006					
		6				DHW preparer low temperature	E007					
		7				Lack of lubrication	E008					
		8				High discharge temperature of Cp1	E009					
		9				Solar collector at high temperature	E010					
		12				Compressor 2 thermal protection	E013					
		13				Fan 2 thermal protection	E014					
		15				Pump thermal protection	E016					
		951				BIT MASK	1	R	-	Alarms ^{4 5}	High temperature	E018
2	High discharge temperature of Cp2		E019									
3	Inverted pressure transducers		E020									
6	Compressor 3 thermal protection		E023									
7	Fan 3 thermal protection		E024									
9	Pump 2 thermal protection		E026									
11	Incongruent temperatures		E041									
12	Poor heat exchange DHW		E042									
13	DHW accumulation tank in high temperature		E050									
14	I/O module 1 disconnected		E101									
15	I/O module 2 disconnected		E102									
952	BIT MASK		0	R	-		Alarms ^{4 5}				Probe 1 error	E611
			1								Probe 2 error	E621
			2								Probe 3 error	E631
		3	Probe 4 error			E641						
		4	Probe 5 error			E651						
		5	Probe 6 error			E661						
		6	Probe 7 error			E671						
		7	Probe 8 error			E681						
		8	Probe 9 error			E691						
		9	Probe 10 error			E701						
		10	Probe 11 error			E711						
		11	Module 1 probe 1 error			E612						
		12	Module 1 probe 2 error			E622						
		13	Module 1 probe 3 error			E632						
		14	Module 1 probe 4 error			E642						
		15	Module 1 probe 5 error			E652						

Register	Format	Bit	R/W	Range	Name	Description	Note					
953	BIT MASK	0	R	-	Alarms ^{4 5}	Module 1 probe 6 error	E662					
		1				Module 1 probe 7 error	E672					
		2				Module 1 probe 8 error	E682					
		3				Module 1 probe 9 error	E692					
		4				Module 1 probe 10 error	E702					
		5				Module 1 probe 11 error	E712					
		6				Module 2 probe 1 error	E613					
		7				Module 2 probe 2 error	E623					
		8				Module 2 probe 3 error	E633					
		9				Module 2 probe 4 error	E643					
		10				Module 2 probe 5 error	E653					
		11				Module 2 probe 6 error	E663					
		12				Module 2 probe 7 error	E673					
		13				Module 2 probe 8 error	E683					
		14				Module 2 probe 9 error	E693					
		954				BIT MASK	15	R	-	Alarms ^{4 5}	Module 2 probe 10 error	E703
0	Module 2 probe 11 error		E713									
1	Link inverter 1		E801									
2	Link inverter 2		E802									
3	Link inverter 3		E803									
4	Hardware fault inverter 1		E851									
5	Hardware fault inverter 2		E852									
6	Hardware fault inverter 3		E853									
7	Overcurrent inverter 1		E861									
8	Overcurrent inverter 2		E862									
9	Overcurrent inverter 3		E863									
10	High temperature inverter 1		E871									
11	High temperature inverter 2		E872									
12	High temperature inverter 3		E873									
13	Bad voltage inverter 1		E881									
14	Bad voltage inverter 2		E882									
955	BIT MASK	15	R	-	Alarms ^{4 5}	Bad voltage inverter 3	E883					
		0				Phase sequence inverter 1	E891					
		1				Phase sequence inverter 2	E892					
		2				Phase sequence inverter 3	E893					
		3				Model error inverter 1	E901					
		4				Model error inverter 2	E902					
		5				Model error inverter 3	E903					
		6				Overload error inverter 1	E911					
		7				Overload error inverter 2	E912					
		8				Overload error inverter 3	E913					
		9				Overcurrent PFC inverter 1	E921					
		10				Overcurrent PFC inverter 2	E922					
		11				Overcurrent PFC inverter 3	E923					
							12				Internal communication error inverter 1	E931
							13				Internal communication error inverter 2	E932
							14				Internal communication error inverter 3	E933
15	Fault PFC inverter 1		E941									

Register	Format	Bit	R/W	Range	Name	Description	Note
956	BIT MASK	0	R	-	Alarms ^{4 5}	Fault PFC inverter 2	E942
		1				Fault PFC inverter 3	E943
		2				Probe error inverter 1	E951
		3				Probe error inverter 2	E952
		4				Probe error inverter 3	E953
		5				Abnormal condition inverter 1	E961
		6				Abnormal condition inverter 2	E962
		7				Abnormal condition inverter 3	E963
		8				Inverter 1 EEPROM error	E971
		9				Inverter 2 EEPROM error	E972
		10				Inverter 3 EEPROM error	E973
		11				High discharge temperature of Cp3	E029
		12				Anti-legionella performed correctly	E060
		13				Anti-legionella failed or stopped	E061

¹⁾ if enabled

²⁾ the cycle is activated only if the DHW (4-5-6) status is terminated by the machine.

³⁾ if the read value is equal to 32766 the probe is not configured, if 32767 the probe is faulty.

⁴⁾ reset alarms, write the value 0 with the command 6 on any of the registers of the alarms area.

⁵⁾ the alarms of circuit 2 are mapped in the same way with an offset of 20000 (e.g. 20950).

⁶⁾ function present on FW with revision 023 and later, up to size 32kW

Restart control, write with command 6 the value -3856 (without sign 61680) to register 200, only with compressor stopped.

